

TELEDYNE HASTINGS INSTRUMENTS



INSTRUCTION MANUAL

HFM-E-200/HFC-E-202 SERIES
FLOWMETERS/CONTROLLERS



ISO 9001
CERTIFIED

Manual Print History

The print history shown below lists the printing dates of all revisions and addenda created for this manual. The revision level letter increases alphabetically as the manual undergoes subsequent updates. Addenda, which are released between revisions, contain important change information that the user should incorporate immediately into the manual. Addenda are numbered sequentially. When a new revision is created, all addenda associated with the previous revision of the manual are incorporated into the new revision of the manual. Each new revision includes a revised copy of this print history page.

Revision A (Document Number 138-102002).....	October 2002
Revision B (Document Number 138-102004).....	October 2004
Revision C (Document Number 138-082005)	August 2005
Revision D (Document Number 138-032007)	March 2007
Revision E (Document Number 138-092008).....	September 2008
Revision E (Document Number 138-082010).....	August 2010



Visit www.teledyne-hi.com for WEEE disposal guidance.



CAUTION: The instruments described in this manual are available with multiple pin-outs. Ensure that all electrical connections are correct.



CAUTION: The instruments described in this manual are designed for INDOOR use only.



CAUTION: The instruments described in this manual are designed for Class 2 installations in accordance with IAW/IPC standards

Hastings Instruments reserves the right to change or modify the design of its equipment without any obligation to provide notification of change or intent to change.

Table of Contents

1. INSTALLATION AND OPERATION	4
1.1. FEATURES.....	4
1.2. SPECIFICATIONS.....	5
1.3. OPTIONAL 4-20 mA CURRENT OUTPUT.....	6
1.4. OTHER ACCESSORIES.....	6
1.4.1. Hastings Model 40, THPS-100 and THPS-400 Power Supplies.....	<i>Error! Bookmark not defined.</i>
2. INSTALLATION AND OPERATION	7
2.1. RECEIVING INSPECTION.....	7
2.2. POWER REQUIREMENTS.....	7
2.3. OUTPUT SIGNAL.....	7
2.4. MECHANICAL CONNECTIONS.....	7
2.5. ELECTRICAL CONNECTIONS.....	8
2.6. OPERATION.....	9
2.6.1. Operating Conditions.....	9
2.6.2. Zero Check.....	9
2.6.3. High Pressure Operation.....	10
2.6.4. Blending of Gases.....	10
2.7. OPERATION WITH EXTERNAL DEVICES.....	10
2.7.1. Operation with a Hastings power supply.....	10
2.7.2. Operation with a power supply other than a Hastings.....	10
2.7.3. Operation with an external sensor. (Fig. 2.2).....	11
2.7.4. Soft Start.....	11
2.8. RANGE CHANGING:.....	11
3. THEORY OF OPERATION	12
3.1. OVERALL FUNCTIONAL DESCRIPTION:.....	12
3.2. SENSOR:.....	12
3.3. ELECTRONICS:.....	12
3.4. SHUNT:.....	13
3.5. VALVE:.....	14
4. MAINTENANCE	15
4.1. AUTHORIZED MAINTENANCE.....	15
4.2. TROUBLESHOOTING.....	15
4.3. ADJUSTMENTS.....	16
4.3.1. Calibration Procedure: (Figure 4.1).....	16
4.3.2. Miscellaneous adjustments.....	17
4.4. INLET REMOVAL:.....	17
4.5. PRINTED CIRCUIT BOARD REPLACEMENT.....	17
4.6. SENSOR REPLACEMENT:.....	17
4.7. ORIFICE CHANGES:.....	17
4.7.1. HFC-E-202 Orifice.....	18
4.8. REPLACEMENT PARTS.....	19
5. CONVERSION FACTOR TABLE	20
6. WARRANTY	24
6.1. WARRANTY REPAIR POLICY.....	24
6.2. NON-WARRANTY REPAIR POLICY.....	24
7. DRAWINGS	25
7.1. NOTES:.....	25

1. Installation and Operation

The Hastings HFM-E-200 mass Flow-meter and HFC-E-202 Flow-controller are designed to accurately measure and control mass flow over the range of 10 sccm to 30 slm, without corrections or compensations for gas pressure and temperature with an accuracy of better than $\pm 1\%$ FS. Hastings mass flow instruments do not require any periodic maintenance under normal operating conditions with clean gases. No damage will occur from the use of moderate overpressures (~ 500 psi/3.45MPa) or overflows. Instruments are normally calibrated with the appropriate standard calibration gas (nitrogen) then a correction factor is used to adjust the output for the intended gas

1.1. Features

- **LINEAR BY DESIGN.** The HFM-E-200/HFC-E-202 series is inherently linear (no linearization circuitry is employed). Should recalibration in the field be desired (a calibration standard is required), the customer needs to simply set the zero and span points. There will be no appreciable linearity change of the instrument when the flowing gas is changed.
- **MODULAR SENSOR.** The HFM-E-200/HFC-E-202 series incorporates a removable/replaceable sensor module. Field repairs to units can be achieved with a minimum of production line downtime.
- **LOW TEMPERATURE DRIFT.** The temperature coefficient of span for the HFM-E-200/HFC-E-202 series is typically less than 0.05% of full scale/ $^{\circ}\text{C}$ from 10-50 $^{\circ}\text{C}$. The temperature coefficient of zero is typically less than 0.1 % of reading/ $^{\circ}\text{C}$ from 10-50 $^{\circ}\text{C}$.
- **CURRENT LOOP.** The 4-20 mA option gives the user the advantages of a current loop output to minimize environmental noise pickup.

1.2. Specifications

Accuracy.....	±1% full scale (F.S.)
Repeatability	<±0.125% of F.S.or ±0.075% of rdg. +0.05% F.S. (max)
Maximum operational pressure	500 psi [3.45 MPa] (Option-P- up to 1000 psi [6.9 MPa])
Pressure coefficient	<0.0067% of reading/psi (N2) See pressure section for pressure errors.
Normal operating temperature	10-50°C in non-condensing environment
Operating temperature limits	0-60°C non-condensing
Temperature coefficient (zero)	maximum ±0.085%/°C (from 10 to 50oC)
Temperature coefficient (span)	maximum ±0.05%/°C (from 10 to 50oC)
Leak integrity	<1x10 ⁻⁹ std. cc/s.
Standard flow ranges	5, 10, 20, 50, 100, 200, 500, sccm. 1, 2, 5, 10, 20, 30* slpm (N2 equivalent)
Standard output.....	0-5 VDC (load 2k Ohms)
Optional output	4 -20 mA (load < 600 Ohms when loop return is @ common) (600-1200 Ohm load when loop return is @ -15VDC)
Power requirements.....	+(14 to 16) VDC @ 45 mA, -(14 to 16) VDC @ 185 mA
Wetted materials	302 & 316 stainless steel, nickel 200, Viton (optional), 82/18 Au-Ni braze, Kalrez, silver solder (trace)
Attitude sensitivity of zero	< ±0.25% F.S. for 90° without re-zeroing {N2 at 44.7 psia (308 KPa)}
Controller weight	1.6 lb (0.6 kg) approx.
Meter weight.....	1.6 lb (0.6 kg) approx.
Electrical connector	15 pin subminiature “D”
Standard fittings	1/4” Swagelok®, 1/8” Swagelok®, VCR®, VCO®

* (Specifications may vary for instruments with ranges greater than 10 slpm)

1.3. Optional 4-20 mA Current Output

An option to the standard 0-5 VDC output is the 4-20 mA current output that is proportional to flow. The 4 - 20 mA signal is produced from the 0 - 5 VDC output of the Flowmeter. The current loop output is useful for remote applications where pickup noise could substantially affect the stability of the voltage output.

The current loop signal replaces the voltage output on pin 3 of the "Edge" connector. The current loop may be returned to either the power supply ground or the -15 VDC connections on the power supply. If the current loop is returned to the power supply ground, the load must be between 0 and 600 ohm. If it is returned to the -15VDC, the load must be between 600 and 1200 ohm. Failure to meet these conditions will cause failure of the loop transmitter.

The 4-20 mA I/O option can accept a current input. The 0-5 VDC command signal on pin A can be replaced by a 4-20mA command signal. The loop presets an impedance of 75 ohms and is returned to the power supply through the valve common.

1.4. Other Accessories

1.4.1. Hastings Power supplies

Hastings Power Pod power supply/display units are available in one and four channel versions. They convert 100, 115 or 230VAC to the ± 15 VDC required to operate the flow meter and provide a digital indication of the flow rate. Interface terminals for the retransmission of the flow meter analog output signal are located on the rear of the panel.

The Power Pod 100 and 400 models are built with controllers in mind but will work with meters as well. The Model 40 is for flow meters only. Throughout this manual, when reference is made to a power supply, it is assumed the customer is using a Hastings power supply. Hastings PowerPod-100 and PowerPod-400 power supplies are CE marked, but the Model 40 does not meet CE standards at this time. The Model 40 and PowerPod-100 are not compatible with 4-20 mA analog signals. With the PowerPod 400, individual channels' input signals, as well as their commands, become 4-20 mA compatible when selected. The PowerPod-400 also sports a Totalizer feature. More information about the Power Pods can be found on the Hastings web site. <http://www.teledyne-hi.com/products/powerpod-series.htm>

1.4.2. Interconnecting Cables

Cables are available from Hastings, in various lengths, to connect from the 15 pin "D" connector on the back of the Power Pod directly to any of the 200 series and 300 series flow instruments (including digital versions). More information about the available cables can be found in the Power Pod 400 bulletin on the Hastings web site. <http://www.teledyne-hi.com/pdfs/bulletins.htm>

2. Installation and Operation

This section contains the necessary steps to assist in getting a new Flowmeter/Controller into operation as quickly and easily as possible. Please read the following thoroughly before attempting to install the instrument.

2.1. Receiving Inspection

Carefully unpack the Hastings HFM-E-200/HFC-E-202 series instrument and any accessories that have also been ordered. Inspect for any obvious signs of damage to the shipment. Immediately advise the carrier who delivered the shipment if any damage is suspected. Check each component shipped with the packing list. Insure that all parts are present (i.e., Flowmeter, power supply, cables, etc.). Optional equipment or accessories will be listed separately on the packing list. There may also be one or more OPT-options on the packing list. These normally refer to special ranges or special gas calibrations. They may also refer to special helium leak tests, or high pressure tests. In most cases, these are not separate parts, but special options or modifications built into the Flowmeter.

2.2. Power Requirements

The HFM-E-200/HFC-E-202 series requires ± 15 VDC @ ± 50 mA (HFM-E-200) +50 mA, -200 mA (HFC-E-202) for proper operation. The supply voltage should be sufficiently regulated to no more than 50 mV ripple. The supply voltage can vary from 14.0 to 16.0 VDC. Surge suppressors are recommended to prevent power spikes reaching the instrument. The Hastings power supply described in Section 1.4.2 satisfies these power requirements.

2.3. Output Signal

The standard output of the Flowmeter is a 0-5 VDC signal proportional to the flow rate. In the Hastings power supply the output is routed to the display, and is also available at the terminals on the rear panel. If a Hastings supply is not used, the output is available on pin 3 of the "Edge" connector and is referenced to pin 2. It is recommended that the load resistance be no less than 2k Ω . If the optional 4-20 mA output is used, the load impedance must be selected in accordance with Section 1.3.

2.4. Mechanical Connections

The Flowmeter may be mounted in any position as long as the direction of gas flow through the instrument follows the arrow marked on the bottom of the Flowmeter case label. The preferred orientation is with the inlet and outlet fittings in a horizontal plane (if operating with a dense gas or at high pressures the instrument must be installed horizontally). When mounted in a different orientation the instrument should be re-zeroed at zero flow with the system pressurized to the expected operating pressure.

The smallest of the internal passageways in the HFM-E-200/HFC-E-202 series is the diameter of the sensor tube, which is 0.0125" (0.31 mm), so the instrument requires adequate filtering of the gas supply to prevent blockage or clogging of the tube.

The pressure regulator and the plumbing upstream must be of sufficient size to minimize changes in the upstream pressure. When switching from full flow to zero flow, the inlet pressure of instrument should rise to no more than 30% above the inlet pressure at full flow. In general, high capacity regulators and large internal diameter plumbing help to make the system more stable. The pressure drop between the regulator and the instrument due to line resistance should be minimized. The differential pressure across the unit should be less than 6" of H₂O at maximum flow.

There are two 8-32 threaded holes, located on the bottom of the base that can be used to secure it to a mounting bracket, if desired (screws provided).

The standard inlet and outlet fittings for the 200/202 are 0.25" and 0.125" Swagelok (optional VCR or VCO fittings). The O-rings for the end cap and the sensor are Viton (optional Kalrez or Neoprene). It is

suggested that all connections be checked for leaks after installation. This can be done by pressurizing the instrument (do not exceed 500 psig unless the Flowmeter is specifically rated for higher pressures) and applying a diluted soap solution to the flow connections rated for higher pressures) and applying a diluted soap solution to the flow connections.

2.5. Electrical Connections

If a power supply from Hastings Instruments is used, installation consists of connecting the HFM-E-200/HFC-E-202 series cable from the “D” connector on the rear of the power supply to the “Edge” connector on the top of the Flowmeter. If a different power supply is used, follow the instructions below when connecting the flow meter.

This HFM-E-200/HFC-E-202 series requires Hastings cable #65-854. Use of any other cable can severely damage the instrument and void the warranty. Figure 2.1 shows the schematic layout for connecting the instrument to an appropriate power supply.

The power supply used must be capable of supplying +15VDC at 50mA and -15VDC at -200mA for each controller. These voltages must be referenced to a circuit Common terminal. Connect -15VDC to pin F and +15VDC to pin 4.

Pins 2, B and C are all Commons and they are connected together internally with solder jumpers to ensure compatibility with legacy flow controllers. At least one of these Common pins must be connected to the Common pin on the power supply. However for new designs and for installations with long cable runs between the transducer and the power supply it is recommended that pin C be isolated from the other Common pins of the transducer and provided a separate wire to connect it to the power supply Common.

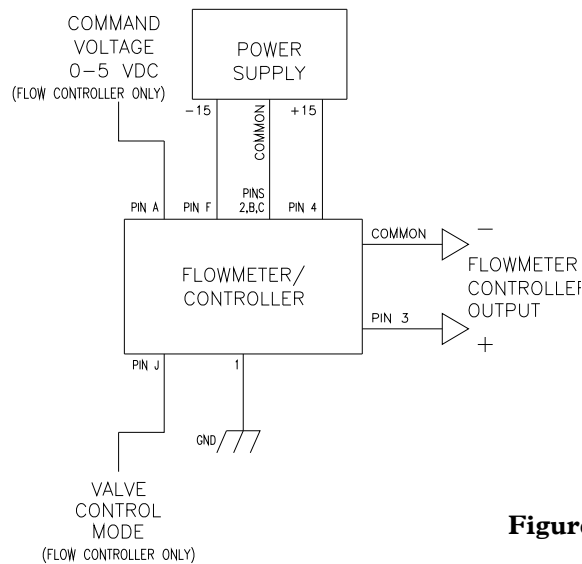
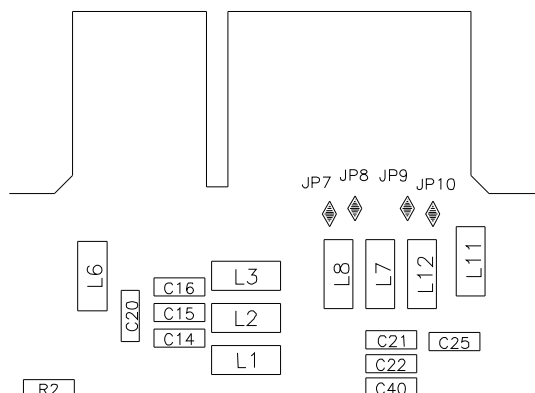

Figure 2.1

This pin carries the valve current and under conditions when the impedance of the wire connecting the transducer Common to the power supply Common is high, tying these Commons together at the transducer can create cross-talk that may result in flow instabilities or errors in the Command signal or the Flow Output signal. In order to isolate pin C, solder jumpers JP8 and JP10 must be unsoldered while JP7 remains soldered. This will be performed at assembly time in the factory if there is an indication at the time of order that this is desired or it can be performed in the field. The Common pins can be reconfigured to put the valve return current on different pins. Consult factory if it is necessary to match previously installed wiring.

Pin 1 is the case ground. It should be connected to the cable shield if available and to the AC ground at the power supply.



Pin 3 is the output signal from the flow controller. This output will be 0-5VDC, 5VDC being 100% of rated or full flow. Pin A is the command input. This should be a 0-5VDC signal and must be free of spikes or other electrical noise, as these will generate false flow commands that the controller would attempt to flow.

If a valve override switch is not desired, the unit is ready for use at this time. If the override switch is desired, connect the center pin of a single pole, three-position switch with the center off position to pin J. Connect +15VDC to one end of the switch, and -15VDC to the other end. This will result in the valve being full open when +15VDC is supplied to pin J, off when -15VDC is supplied and auto-control when there is no connection to pin J (OPEN-AUTO-CLOSE). This setup will be adequate for most purposes, but there will be a small delay for capacitors to charge between switch operation and control override.

2.6. Operation

The standard instrument output is a 0 - 5 VDC out and the signal is proportional to the flow i.e., 0 volts = zero flow and 5 volts = 100% of rated flow. The 4 - 20 mA option is also proportional to flow, 4 mA = zero flow and 20 mA = 100% of rated flow. It is suggested that all connections be checked for leaks after installation. This can be done by pressurizing the instrument (do not exceed 500 psig unless the instrument is specifically rated for higher pressures) and applying a diluted soap solution to the connections.

2.6.1. Operating Conditions

For proper operation, the combination of ambient temperature and gas temperature must be such that the Flowmeter temperature remains between 10 and 50°C. (Most accurate measurement of flow will be obtained if the Flowmeter is zeroed at operating temperature as temperature shifts result in some zero offset.) The HFM-E-201/HFC-E-203 series is intended for use in non-condensing environments only. Condensate or any other liquids which enter the Flowmeter may destroy its electronic components.

2.6.2. Zero Check

Turn the power supply on if not already energized. Allow for a 1 hour warm-up. Stop all flow through the instrument and wait 2 minutes. **Caution:** Do not assume that all metering valves completely shut off the flow. Even a slight leakage will cause an indication on the meter and an apparent zero shift. For the standard 0-5 VDC output, adjust the zero potentiometer located on the lower outlet side of the Flowmeter until the meter indicates zero. For the optional 4-20 mA output, adjust the zero potentiometer so that the meter indicates slightly more than 4 mA, i.e. 4.03 to 4.05 mA. This slight positive adjustment ensures that the 4-20 mA current loop transmitter is not in the cut-off region. The error induced by this adjustment is approximately 0.3% of full scale. This zero should be checked

periodically during normal operation. Zero adjustment is required if there is a change in ambient temperature, or vertical orientation of the Flowmeter/controller.

2.6.3. High Pressure Operation

When operating at high pressure, the increased density of gas will cause natural convection to flow through the sensor tube if the instrument is not mounted in a level position. This natural convection flow will be proportional to the system pressure. This will be seen as a shift in the zero flow output that is directly proportional to the system pressure.

2.6.4. Blending of Gases

In the blending of two gases, it is possible to maintain a fixed ratio of one gas to another. In this case, the output of one flow controller is used as the reference voltage for the set point potentiometer of a second flow controller. The set point potentiometer then provides a control signal that is proportional to the output signal of the first flow controller, and hence controls the flow rate of the second gas as a percentage of the flow rate of the first gas.

EXAMPLE: Flow controller A has 0-10 slpm range with a 5.00 volt output at full scale. Flow controller B has 0-1 slpm range with a 5.00 volt output at full scale. If flow controller A is set at 8 slpm, its output voltage would be 4.00 volts ($8 \text{ slpm}/10 \text{ slpm} \times 5.00 \text{ volts} = 4.00 \text{ volts}$). If the output signal from flow controller A is connected to the command potentiometer of flow controller B, it then becomes a variable reference voltage for flow controller B proportional to the flow rate of flow controller A.

If the set point potentiometer of flow controller B is set at 50% of full scale, and the reference voltage from flow controller A is 4.00, then the command signal going to flow controller B would be 2.00 volts ($4.00 \text{ volts} \times 50.0\% = 2.00 \text{ volts}$). The flow of gas through flow controller B is then controlled at 0.4 slpm ($2.00 \text{ volts}/5.00 \text{ volts} \times 1 \text{ slpm} = 0.4 \text{ slpm}$).

The ratio of the two gases is 20:1 ($8 \text{ slpm}/0.4 \text{ slpm}$). The % mixture of gas A is 95.2 ($8\text{slpm}/84\text{slpm}$) and the % mixture of gas B is 4.8% ($0.4 \text{ slpm}/8.4 \text{ slpm}$).

Should the flow of flow controller A drop to 7.8 slpm, flow controller B would drop to 0.39 slpm, hence maintaining the same ratio of the mixture. ($7.8 \text{ slpm}/10 \text{ slpm} \times 5\text{v} = 3.90\text{v}$; $3.90\text{v} \times 50\% = 1.95\text{v}$; $1.95\text{v}/5.00\text{v} \times 1 \text{ slpm} = 0.39 \text{ slpm}$; $7.8 \text{ slpm} : 0.39 \text{ slpm} = 20:1$)

2.7. Operation with External Devices

2.7.1. Operation with a Hastings power supply.

There are two controls for each flow controller connected to a Hastings power supply. A switch labeled "OPEN; AUTO; CLOSED" (valve over ride THPS 400 only) and a potentiometer labeled "COMMAND". For normal operation, the valve over ride switch will be in the "AUTO" position. The "CLOSE" position removes all power from the valve, shutting off flow regardless of the command pot setting. The "OPEN" position applies full available valve voltage to the valve, causing it to open, regardless of the command pot setting. The "OPEN" position is useful for purging systems. It is recommended that the valve over ride switch not be left in this position for extended periods of time, with no flow through the controller, as a small positive zero shift may be observed.

The "COMMAND" pot adjusts the Analog command signal sent to the flow controller. The setting for each controller connected to the power supply can be observed. (Depending on how the power supply was set up, the display could indicate in flow units or percent of full scale).

2.7.2. Operation with a power supply other than a Hastings.

The flow controller must be connected to the power source as specified in section 2.6. In general, a 0-5 VDC command signal proportional to the intended flow (0 volts = zero flow; 5 volts = 100% of rated flow) must be applied to pin A of the "Edge" connector. A 0-5 VDC signal proportional to the flow rate through the instrument will be present on pin 3 of the "Edge" connector. The control mode is selected via pin J of the "Edge" connector. Apply +15 volts for full open, -15 volts for closed and allow pin J to float for flow proportional to the command voltage. Refer to your power supply manual for the specifics of implementing these parameters.

2.7.3. Operation with an external sensor. (Fig. 2.2)

In some instances, it might be desirable to use an external sensor to provide process information to the control circuitry in the flow controller. For example, you might want to control the pressure in a vacuum system by adjusting the rate at which the system is backfilled with a gas. The new, enhanced HFC series of flow controllers have provision for accepting a 0-5VDC output from an external sensor at pin 8 of the "Edge" connector. To activate this feature, the cover of the HFC must be removed to gain access to PC-888 and move a jumper on JP3. JP3 is a three pin jumper block located just below the "Edge" connector. In the normal operating mode, the jumper covers the bottom two pins. To select "External Sensor", move the jumper to the upper two pins. This swaps the flow input to the controller circuit from the Flowmeter output to pin 8 of the "Edge" connector.

2.7.4. Soft Start

The response of the control circuit to sudden changes in the Command signal is set at the factory for fast, stable response and minimal overshoot. If any overshoot is a problem in a particular system, it is possible to slow down the controller response to sudden Command changes. Remove the outer cover from the instrument and remove pin jumper JP6 this will insert an R-C filter with a two second time constant into the command circuit. This will slow down the reaction of the controller to step changes in the Command signal and will ensure that there is no overshoot or undershoot in actual gas flow.

2.8. Range Changing:

The range of the flow controller can be changed in the field if recalibration facilities are available. The flow controller may require a different orifice and different laminar Flowmeter element (shunt), which can be purchased separately from the factory. A listing of the orifices and shunts are available and their flow rates can be found in Section 4.8.

The range of the small tube shunts can be changes by changing the front disk, consult factory for more information on disk options.

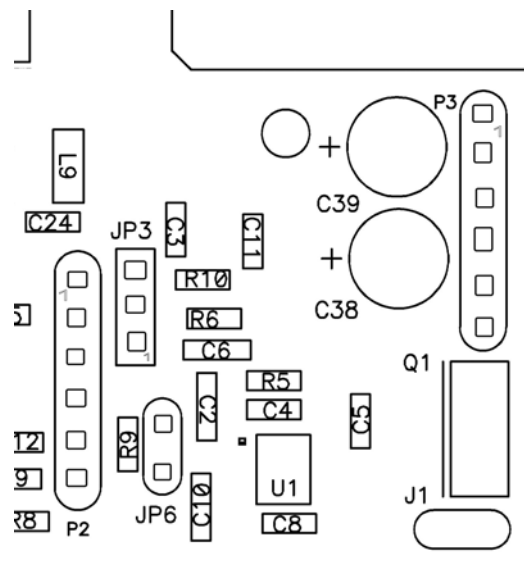

Figure 2.1

3. Theory of Operation

This section contains an overall functional description of HFC Flow Controllers. Detailed schematics and parts lists can be found at the end of the manual in Section 6.0. In this section and other sections throughout this manual, when a power supply is mentioned, it is assumed that the customer has a Hastings Power Supply. These sections are not applicable if another type of power supply is used.

3.1. Overall Functional Description:

The HFC Flow Controller consists of a sensor, electronic circuitry, a shunt and a valve. The sensor measures the flow rate from 0 to 10 sccm of the gas to be metered. The shunt divides the flow such that the flow through the sensor is a precise percentage of the flow through the shunt. The flow through the sensor and the shunt is always laminar. The circuit board amplifies the sensor output and uses this output to control the valve position. The valve is an automatic metering solenoid type; its height off the seat is controlled by the voltage in its coil. All of these components working together result in a fast, stable flow controller.

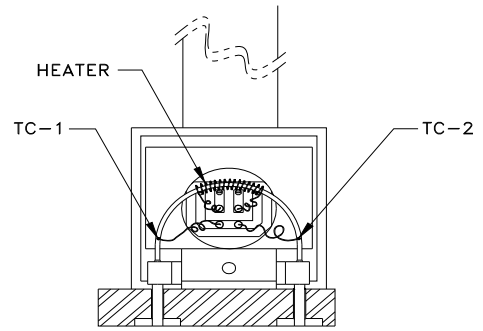

Figure 3.1

3.2. Sensor:

The Hastings HFM-E-200/HFC-E-202 series operates on a unique thermal electric principle whereby a metallic capillary tube is heated uniformly by a resistance winding attached to the midpoint of the capillary (see Figure 3.1). Thermocouples TC-1 and TC-2 are welded at equal distances from the midpoint and develop equal outputs at zero flow.

When flow occurs through the tubing, heat is transferred from the tube to the gas on the inlet side, and from the gas back to the tube on the outlet side creating an asymmetrical temperature distribution (see Figure 3.2). The thermocouples sense this decrease and increase in the capillary tube temperature and produce a millivolt output signal proportional to that change.

For a constant power input, the differential thermocouple output is a function of the mass flow rate and the heat capacity of the gas. Since the heat capacity of many gases is relatively constant over wide ranges of temperature and pressure, the Flowmeter may be calibrated directly in mass units for those gases. Changes in gas composition usually only require application of a simple multiplier to the air calibration to account for the difference in heat capacity and thus the Flowmeter is capable of measuring a wide variety of gases. The HFM sensor measures approximately 10 sccm. Full scale flow.

3.3. Electronics:

The Hastings HFM-E-200/HFC-E-202 series uses a thermal flow sensor to measure through a capillary tube, which is a fixed percentage of the total flow through the instrument. This sensor develops an output signal proportional to flow which is approximately 1 mv full scale magnitude. This signal is amplified by the meter circuitry until is 0-5.00 VDC. This 5 volt output is sent back to the power supply and to the Flowmeter circuitry, if applicable. At the power supply the 5 volt output is sent to the terminals on the back and to the decoding circuitry in the display which converts it to a 3-digit output.

The controller circuitry utilizes the Command and the Flow voltages as input signals. The 0-5VDC command signal is subtracted from the 0-5VDC flow signal creating an error signal. This signal is amplified and causes the solenoid valve to move. The amount and direction of the movement is dependent upon the value and the sign of the error signal, and tends to minimize the error signal.

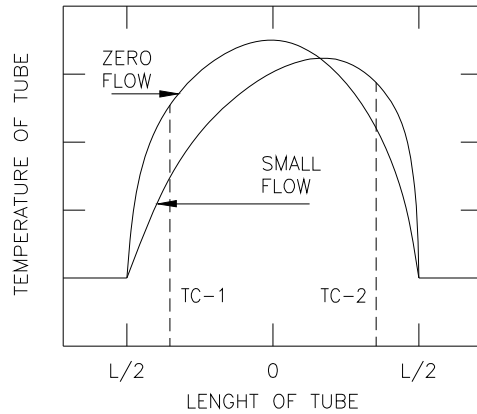

Figure 3.2

3.4. Shunt:

Measurement of flow rates higher than the 10 sccm full scale is achieved by dividing the flow with a fixed ratio shunting arrangement, as is illustrated in Figure 3.3. This is accomplished by placing the measuring capillary tube parallel with one or more dimensionally similar channels, called a laminar flow element (LFE). Therefore, the sensor only needs to heat the gas passing through the capillary tube resulting in low power requirements, while retaining all the mass measuring characteristics.

The HFM-E-200/HFC-E-202 series has many different shunts. The low range shunt consists of tubes inserted into a cylindrical base. This shunt is adjustable for ranges from 0-10 sccm to 0-180 sccm (see Figure 3.4). The medium range shunts consists of a piece of stainless steel foil welded to a solid steel center core. The high range shunts consists of a corrugated stainless steel ribbon wound into a coil and fused.

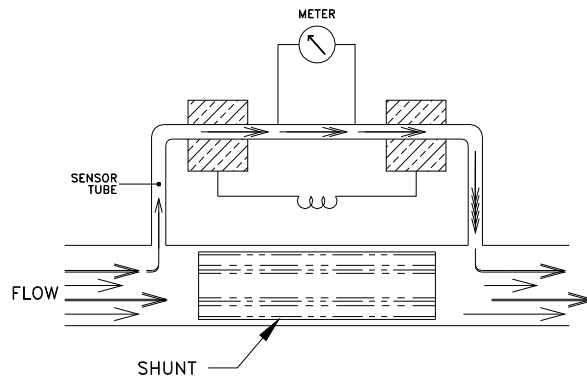

Figure 3.3

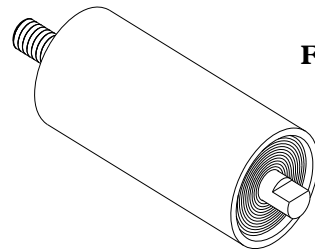

Figure 3.4

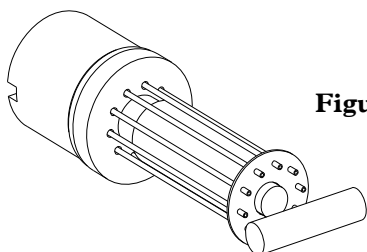
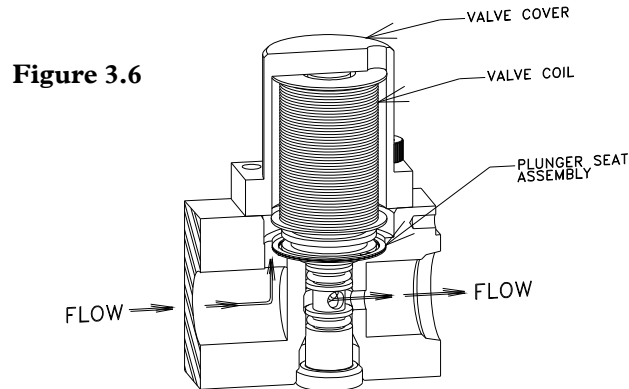

Figure 3.5

3.5. Valve:

The control valve is an “automatic metering solenoid” valve. While most solenoids operate in either the fully open or fully closed state, the automatic metering solenoid valve is designed to control flow (see Figure 3.6). A spring, connected to the plunger assembly, holds a magnetic plunger tightly against an orifice to shut off flow. The magnetic plunger is surrounded by an electrical coil, which when energized with electrical current lifts the plunger off the orifice and allows flow to pass between the orifice and the plunger seat. Controlling the current through the coil controls the distance between the orifice and the plunger seat, thus effectively controlling the flow through the valve. This current is controlled by a feedback loop that matches the transducer output with the command voltage.



4. Maintenance

This section contains service and calibration information. Some portions of the instrument are delicate. Use extreme care when servicing the flow controller. The potentiometer positions and the electrical components referred to in the troubleshooting section can be found in Section 6.0 on the electrical component layout drawing.

4.1. Authorized Maintenance

With proper care in installation and use, the flow controller will require little or no maintenance. If maintenance does become necessary, most of the instrument can be cleaned or repaired in the field. Some procedures may require recalibration. Do not attempt these procedures unless facilities are available. Entry into the sensor or tampering with the printed circuit board will void warranty. Do not perform repairs on these assemblies while unit is still under warranty.

4.2. Troubleshooting

SYMPTOM: Output reads 40% of flow with no flow. Zero pot has no effect.

CAUSE: Power supply locked up or shorted out.

ACTION: Turn off power supply for a few seconds, then turn back on. If this proves ineffective, disconnect the unit from the power supply. If power supply display does not return to zero, then a regulator chip in the power supply is probably burned out. Check supply voltages and replace faulty regulator. If display returns to zero after disconnecting the power supply from the unit there is a short in the unit to ground. Check capacitors C38 & C39 first.

SYMPTOM: Command is zero, but flow remains.

CAUSE: Orifice out of adjustment or faulty op-amp

ACTION: Check valve voltage at connector pins C & D. If voltage is less than 3.00 VDC, then turn orifice clockwise until flow stops. If voltage is greater than 3.00 VDC. Replace PC Board.

SYMPTOM: Output of unit is proportional to flow but extremely small and not correctable by span pot.

CAUSE: Sensor is not being heated.

ACTION: Unplug connector J2. Check the following resistance: The resistance between pins 2 & 3 of the sensor should be approximately 2500 ohms (see Figure 3.1 on page 8). The resistance between pins 1 & 4 should be approximately 2.3 ohms. The resistance between pins 2 & 3 and the base of the sensor should be essentially infinite. If not, replace the sensor unit. If sensor reads O.K., check the voltage output on pins 2 & 3 of the jack in the board. If it does not read approximately 22 VDC then replace PC Board.

SYMPTOM: Sensor has proper resistance readings, but little or no output with flow.

CAUSE: Plugged sensor.

ACTION: Shut off gas supply and power supply. Remove cover and PC board from unit. Remove sensor assembly and examine. If sensor has evidence of plugging, clean or replace as applicable

SYMPTOM: Flow controller oscillates.

CAUSE: Flow controller not adjusted for the dynamics of the flow system.

ACTION: Check upstream and downstream pressures. The gas supply regulator should not have excessive lockup when flow shuts off. Also ensure that there is not a large drop in pressure between the regulator and the instrument due to line resistance. Oscillations can also be caused if a large flow restriction is pneumatically close to the downstream end of the flow controller. The differential pressure across the unit must be between the values specifications on the original order.

SYMPTOM: Little or no flow, even with a maximum SetPoint value.

CAUSE: Plugged orifice.

ACTION: Verify the presence of a pressure across the instrument. If present, shut off gas supply and power supply. Remove orifice per Section 4.9. Examine orifice. If plugged, clean or replace as applicable. Reassemble valve.

SYMPTOM: Flowmeter reads other than 0.00 VDC with no flow, or there is a small flow when Flowmeter reads 0.00 VDC.

CAUSE: ZERO potentiometer is out of adjustment.

ACTION: Shut off all flow. Adjust ZERO potentiometer until output reads 0.00 VDC.

SYMPTOM: Flowmeter out of calibration and nonlinear.

CAUSE: Leaks in gas inlet or outlet fittings.

ACTION: Check all fittings for leaks by placing soap solution on all fittings between gas supply and final destination of gas. Check Flowmeter for leaks. Replace "O" rings if required or recalibrate as necessary.

4.3. ADJUSTMENTS

4.3.1. Calibration Procedure: (Figure 4.1)

NOTE: Adjusting the SPAN pot will require the use of a calibration reference in Step 5.

1. Connect power cable to Edge Connector as specified in Section 2.7. Allow instrument to warm up for 30 minutes. Ensure that for at least the last 3 minutes there is a controlled flow of gas through the instrument, shut off gas flow, wait 2 minutes.
2. Set ZERO (R19) potentiometer for 0.000 VDC output.
3. Turn on gas supply to inlet of instrument. Put Valve Override switch into CLOSE position. Adjust the orifice underneath controller to obtain zero flow. Put Valve Override switch into AUTO. Ensure that full range flow can still be obtained at minimum inlet pressure.
4. Set command to 100%. Wait 2 minutes; adjust SPAN (R29) pot until the flow reference reads full scale flow (5.000 VDC). **NOTE:** Perform this step only if a calibrated reference Flowmeter is available.
5. Record Flowmeter and flow reference outputs for flow rates of 20%, 40%, 60%, 80% and 100%.

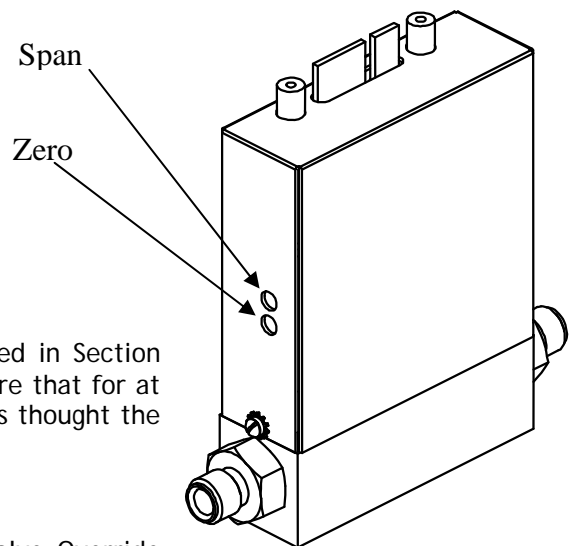

4.3.2. Miscellaneous adjustments

Periodically, during normal operation, the ZERO should be checked and adjusted when required. If the instrument is not stopping the flow completely when command signal is Zero, the orifice may require turning approximately 1/8 turn clockwise.

4.4. Inlet Removal:

The fitting on the inlet side must be removed to gain access to the filter or shunt assembly. First shut off the supply of gas to the instrument. Disconnect the Swagelok fitting on the inlet and outlet sides of the transducer, and remove it from the system plumbing. Carefully remove the inlet fitting, spring (if present) and shunt, noting their order and proper orientation. The shunt can be severely damaged if dropped. Examine the filter and shunt. If either is dirty or blocked, clean or replace as applicable. Reassembly is the reverse of the removal procedure. **Recalibration of the HFC is necessary.**

4.5. Printed Circuit Board Replacement

In the unlikely event that the PC board fails, it is easily removed from the instrument and replaced with a spare to minimize instrument downtime. Replacement of the PC board will require the instrument to be recalibrated per Section 4.3.1.

Unplug the power cable from the top of the transducer. Remove the two jackscrews next to the "Edge" connector and the two screws on the sides of the cover. Lift off the cover and unplug the four-wire sensor plug and the two wire valve plug, noting their orientation prior to removal.

Remove the screw that holds the PC board to the sensor. Troubleshoot or replace as applicable. Installation is the reverse of the above procedure. Recalibrate if any components were changed or if any potentiometers were adjusted.

4.6. Sensor Replacement:

If the sensor fails or becomes plugged it can be removed. Remove the cover and the PC board per Section 4.5 above. Remove the three bolts holding the sensor to the instrument base. Remove the sensor from the base noting the two O-rings (Parker 2-005, V884-75) between the sensor and the base. If the sensor is plugged it can be cleaned by running a fine wire (approximately 0.008" diameter) through the tube. If sensor needs replacement, obtain another from the factory and install it. Ensure that O-rings are clean and intact. Install O-rings on seating surface, then carefully place sensor over O-rings and tighten down the three screws evenly. Replacement of sensor will require recalibration per Section 4.3.1.

4.7. Orifice Changes:

The orifice may require replacement if a flow range change is desired, if a large change in differential pressures across the valve is desired or in the event that a small orifice becomes plugged. Replacement orifices can be acquired from the factory. See Section 4.8 for the list of standard orifices and their flow rates in air.

When using nonstandard pressures or gases that have specific gravities different than air (such as hydrogen or helium), the diameter of the orifice must be calculated using the following procedure:

- A) Determine the minimum expected upstream pressure (P_u) in PSI absolute and the maximum expected downstream pressure (P_d) in PSI absolute for full flow conditions.
- B) If $P_u > 2P_d$, use formula 1; otherwise use formula 2.

Where:

Formula 1:

$$D = \sqrt{\frac{0.0028\sigma Q}{P_u}}$$

Formula 2:

$$D = \sqrt{\frac{0.0014Q}{\sqrt{\frac{\Delta P \cdot Pd}{\sigma}}}}$$

D = Diameter in inches

Q = Flow rate in standard liters per minute

P = $P_u - P_d$ in PSI

P_u = Upstream pressure in PSIA

P_d = Downstream pressure in PSIA

σ = Specific gravity of gas

Choose the orifice form Section 5.0 that has the closes larger diameter to the calculated diameter.

4.7.1. HFC-E-202 Orifice

To change the orifice in the HFC-E-202 series, turn the instrument upside-down and turn the orifice counterclockwise with a 9/64" Allen wrench until it stops coming out. Then grasp the exposed orifice end and pull it straight out. See Figure 4.2.

Prior to reinstallation of the orifice, inspect the two O-rings mounted on it for damage. Replace if cut or gouged.

Lubricate the O-rings slightly with a silicone based grease, and the threads with anti-galling compound. Push the orifice into its hole and screw it in until it is flush with the instrument base. Apply pressure to the inlet side of the instrument.

Turn the Valve Override switch to CLOSE or unplug the instrument. Screw the orifice in a few more turns until the flow through the instrument stops, then turn it an additional 1/8 turn clockwise.

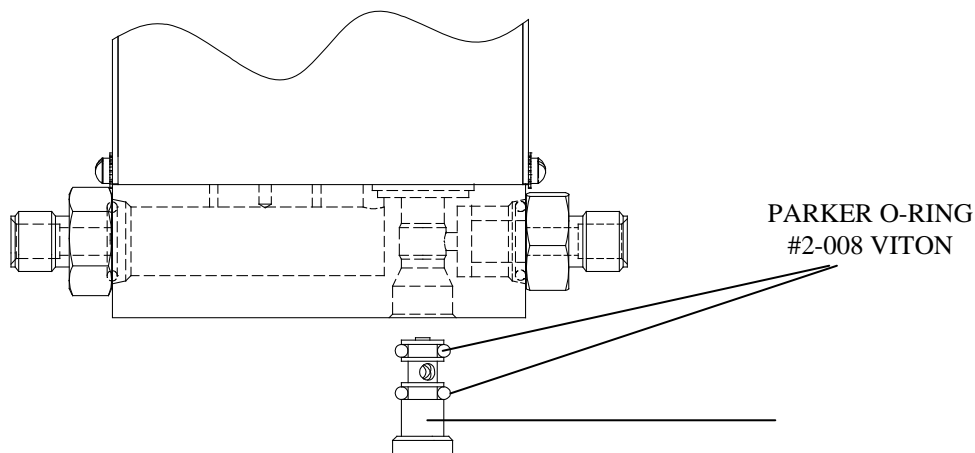

Fig 4.2

4.8. REPLACEMENT PARTS

The following is a list of the available replacement parts and their factory stock numbers. The HFM-E-200 and the HFC-E-202 shunts and sensor modules are interchangeable.

STOCK NO.	DESCRIPTION	AIR RANGE
81-270	30L - Shunt	24 - 36
81-269	20L - Shunt	16 - 24
81-268	10L - Shunt	8 - 12
81-267	5L - Shunt	4 - 6
81-266	2L - Shunt	1.6 - 2.4
	1L - Shunt	0.8 - 1.2
81-265	500sccm - Shunt	400 - 600
81-263	150sccm - Shunt	120 - 180
81-262	70sccm - Shunt	60 - 132
81-261	20sccm - Shunt	12 - 60
81-260	10sccm - Shunt	8 - 12
28-13-298	Orifice 0.001"	
28-13-299	Orifice 0.002"	
28-13-167	Orifice 0.003"	
28-13-168	Orifice 0.007"	
28-13-169	Orifice 0.014"	
28-13-171	Orifice 0.032"	
28-13-172	Orifice 0.052"	
28-13-173	Orifice 0.070"	
81-314	SENSOR MODULE	ALL MODELS

NOTE: Ranges listed are for Nitrogen.

To place an order or to obtain information concerning replacement parts, contact the factory or our local manufacturer's representative in your area. See below, or this manual's last page for the address or phone number. When ordering, include the following information:

Instrument model number

Part description

Hastings part number

5. Conversion Factor Table

Rec #	Gas	Symbol	GCF	Derived	Density	Density	Synonyms	Gamma	R	Z
					(g/L) 25°C / 1 atm	(g/L) 0°C / 1 atm		(Cp/Cv) 25	J/gm*K	
1	Acetic Acid	C ₂ H ₄ F ₂	0.4155	4	2.700	2.947	Ethanoic Acid	1.2	125.88	2.0301
2	Acetic Acid, Anhydride	C ₄ H ₆ O ₃	0.2580	4	4.173	4.555	Aceticanhydride	1.2	81.44	2.3384
3	Acetone	C ₃ H ₆ O	0.3556	4	2.374	2.591	2-propanone	1.2	143.16	1.7504
4	Acetonitril	C ₂ H ₃ N	0.5178	4	1.678	1.832	Methyl Cyanide	1.2	202.54	1.4462
5	Acetylene	C ₂ H ₂	0.6255	4	1.064	1.162	Ethyne	1.23	319.33	0.9792
6	Air	Air	1.0015	1	1.185	1.293	NA	1.4	287.00	1.0930
7	Allene	C ₃ H ₄	0.4514	4	1.638	1.787	Propadiene	1.2	207.53	1.3876
8	Ammonia	NH ₃	0.7807	2	0.696	0.760	NA	1.32	488.21	0.6409
9	Argon	Ar	1.4047	1	1.633	1.782	NA	1.66	208.13	2.1243
10	Arsine	AsH ₃	0.7592	5	3.186	3.478	NA	1.2	106.67	4.0839
11	Benzene	C ₆ H ₆	0.3057	4	3.193	3.485	NA	1.2	106.44	2.0636
12	Boron Trichloride	BCl ₃	0.4421	4	4.789	5.228	NA	1.2	70.96	3.6531
13	Boron Trifluoride	BF ₃	0.5431	4	2.772	3.025	NA	1.2	122.62	2.4109
14	Bromine	Br ₂	0.8007	4	6.532	7.130	NA	1.4	52.03	1.0000
15	Bromochlorodifluoromethane	CBrClF ₂	0.3684	4	6.759	7.378	NA	1.2	50.28	4.2789
16	Bromodifluoromethane	CHBrF ₂	0.4644	4	5.351	5.841	NA	1.2	63.51	4.3990
17	Bromotrifluoromethane	CBrF ₃	0.3943	4	6.087	6.644	NA	1.2	55.84	4.1546
18	Butane	C ₄ H ₁₀	0.2622	2	2.376	2.593	NA	1.09	143.05	1.6896
19	Butanol	C ₄ H ₁₀ O	0.2406	4	3.030	3.307	1-Butanol, Butyl Alcohol	1.2	112.17	1.9233
20	Butene	C ₄ H ₈	0.3056	4	2.293	2.503	1-Butene, 1-Butylene	1.2	148.19	1.6700
21	Carbon Dioxide	CO ₂	0.7526	1	1.799	1.964	NA	1.22	188.93	1.7511
22	Carbon Disulfide	CS ₂	0.6160	4	3.112	3.397	NA	1.2	109.20	3.0744
23	Carbon Monoxide	CO	1.0012	4	1.145	1.250	NA	1.4	296.84	1.0433
24	Carbon Tetrachloride	CCl ₄	0.3333	4	6.287	6.863	Tetrachloromethane	1.2	54.05	3.6196
25	Carbonyl Sulfide	COS	0.6680	4	2.456	2.680	Carbon Oxysulfide	1.2	138.40	2.4230
26	Chlorine	Cl ₂	0.8451	4	2.898	3.163	NA	1.4	117.26	3.9995
27	Chlorine Trifluoride	ClF ₃	0.4496	5	3.779	4.125	NA	1.2	89.94	2.8970
28	Chlorobenzene	C ₆ H ₅ Cl	0.2614	4	4.601	5.022	NA	1.2	73.87	2.4954
29	Chlorodifluoroethane	C ₂ H ₅ ClF ₂	0.3216	4	4.108	4.484	Ethane, 2-chloro-1,1-difluoro-	1.2	82.74	2.5119
30	Chloroform	CHCl ₃	0.4192	4	4.879	5.326	Trichloromethane	1.2	69.65	3.5284
31	Chloropentafluoroethane	C ₂ ClF ₅	0.2437	4	6.314	6.892	NA	1.2	53.83	2.9778
32	Chloropropane	C ₃ H ₇ Cl	0.3080	4	3.210	3.504	Propylchloride	1.2	105.86	2.0756
33	Cisbutene	C ₄ H ₈	0.3004	4	2.293	2.503	Cis-2-butene	1.2	148.19	1.6672
34	Cyanogen	C ₂ N ₂	0.4924	4	2.127	2.322	NA	1.2	159.79	1.7626
35	Cyanogen Chloride	ClCN	0.6486	5	2.513	2.743	NA	1.2	135.26	2.4405
36	Cyclobutane	C ₄ H ₈	0.3562	4	2.293	2.503	Tetramethylene	1.2	148.19	1.7091
37	Cyclopropane	C ₃ H ₆	0.4562	4	1.720	1.877	Trimethylene	1.2	197.59	1.4440
38	Deuterium	H ₂ ²	1.0003	4	0.165	0.180	D ₂	1.4	2062.13	0.3102
39	Diborane	B ₂ H ₆	0.5063	5	1.131	1.235	NA	1.2	300.49	1.0486
40	Dibromodifluoromethane	CBr ₂ F ₂	0.3590	4	8.576	9.361	NA	1.2	39.63	5.2998
41	Dichlorofluoromethane	CHCl ₂ F	0.4481	4	4.207	4.592	R21	1.2	80.78	3.2249
42	Dichloromethane	CH ₂ Cl ₂	0.5322	4	3.472	3.789	Methylene Chloride	1.2	97.90	3.0592
43	Dichloropropane	C ₃ H ₆ Cl ₂	0.2698	4	4.618	5.041	1,2-dichloropropane,	1.2	73.59	2.5291
44	Dichlorosilane	H ₂ SiCl ₂	0.4716	5	4.129	4.506	NA	1.2	82.32	3.3176
45	Diethyl Amine	C ₄ H ₁₁ N	0.2256	4	2.989	3.263	NA	1.2	113.68	1.9080
46	Diethyl Ether	C ₄ H ₁₀ O	0.2235	4	3.030	3.307	1,1-oxybisethane	1.2	112.17	1.9215
47	Diethyl Sulfide	C ₄ H ₁₀ S	0.2255	4	3.686	4.024	3-thiapentane, UN-2375	1.2	92.19	2.1300

48	Difluoroethylene	C ₂ H ₂ F ₂	0.4492	4	2.617	-	2.857	-	Vinylidene fluoride, G-1132A, Difluoroethene	1.2	129.85	2.0457
49	Dimethylamine	C ₂ H ₇ N	0.3705	4	1.843	-	2.011	-	N-methylmethanamine	1.2	184.42	1.4793
50	Dimethyl Ether	C ₂ H ₆ O	0.4088	4	1.883	-	2.055	-	Methylether; Methane, Oxybis-	1.2	180.48	1.5211
51	Dimethyl Sulfide	C ₂ H ₆ S	0.3623	4	2.540	-	2.772	-	2-thiopropene, Thiobismethane	1.2	133.81	1.8455
52	Divinyl	C ₄ H ₆	0.3248	4	2.211	-	2.413	-	1,3-butadiene	1.2	153.71	1.6433
53	Ethane	C ₂ H ₆	0.4998	2	1.229	-	1.342	-	NA	1.19	276.51	1.1175
54	Ethane, 1-chloro-1,1,2,2-tetrafluoro-	C ₂ HClF ₄	0.2684	4	5.578	-	6.089	-	Chlorotetrafluoroethane	1.2	60.92	2.8629
55	Ethane, 1-chloro-1,2,2,2-tetrafluoro-	C ₂ HClF ₄	0.2719	4	5.578	-	6.089	-	Chlorotetrafluoroethane	1.2	60.92	2.8806
56	Ethanol	C ₂ H ₆ O	0.4046	4	1.883	-	2.055	-	Ethyl Alcohol	1.2	180.48	1.5187
57	Ethylacetylene	C ₄ H ₆	0.3256	4	2.211	-	2.413	-	1-butyne	1.2	153.71	1.6438
58	Ethyl Amine	C ₂ H ₇ N	0.3694	4	1.843	-	2.011	-	Ethanamine	1.2	184.42	1.4789
59	Ethylbenzene	C ₈ H ₁₀	0.2001	4	4.339	-	4.737	-	1-butyne	1.2	78.32	2.3099
60	Ethyl Bromide	C ₂ H ₅ Br	0.4124	4	4.454	-	4.862	-	NA	1.2	75.60	3.1724
61	Ethyl Chloride	C ₂ H ₅ Cl	0.4212	4	2.637	-	2.878	-	Chloroethane	1.2	128.88	2.0018
62	Ethyl Fluoride	C ₂ H ₅ F	0.4430	4	1.964	-	2.144	-	Fluoroethane, R-161	1.2	173.00	1.5967
63	Ethylene	C ₂ H ₄	0.6062	1	1.147	-	1.252	-	Ethene	1.21	296.38	1.0475
64	Ethylene Dibromide	C ₂ H ₄ Br ₂	0.3173	4	7.679	-	8.382	-	1,2-dibromoethane	1.2	44.26	4.1196
65	Ethylene Dichloride	C ₂ H ₄ Cl ₂	0.3475	4	4.045	-	4.415	-	1,2-dichloroethane	1.2	84.02	2.5846
66	Ethylene Oxide	C ₂ H ₄ O	0.5308	4	1.801	-	1.965	-	Acetaldehyde	1.2	188.74	1.5495
67	Ethyleneimine	C ₂ H ₄ N	0.4790	4	1.719	-	1.877	-	Aziridine	1.2	197.71	1.4552
68	Ethylidene Dichloride	C ₂ H ₄ Cl ₂	0.3506	4	4.045	-	4.415	-	1,1-dichloroethane	1.2	84.02	2.5976
69	Ethyl Mercaptan	C ₂ H ₆ S	0.3654	4	2.540	-	2.772	-	Ethanethiol	1.2	133.81	1.8499
70	Fluorine	F ₂	0.9115	4	1.553	-	1.695	-	NA	1.4	218.82	1.5574
71	Formaldehyde	CH ₂ O	0.7912	4	1.227	-	1.340	-	NA	1.2	276.91	1.1232
72	Freon 11	CCl ₃ F	0.3535	4	5.615	-	6.129	-	Trichloro,fluoromethane	1.2	60.53	3.4473
73	Freon 12	CCl ₂ F ₂	0.3712	4	4.942	-	5.395	-	Dichloro,difluoromethane	1.2	68.76	3.2026
74	Freon 13	CClF ₃	0.3792	4	4.270	-	4.661	-	Chloro, trifluoromethane	1.2	79.60	2.8572
75	Freon 14	CF ₄	0.4422	4	3.597	-	3.926	-	Carb. Tetrafluoride, Meth. Tetrafluoride	1.2	94.48	2.7242
76	Freon 22	CHClF ₂	0.4857	4	3.534	-	3.858	-	Chloro, difluoromethane	1.2	96.16	2.8794
77	Freon 23	CHF ₃	0.5282	4	2.862	-	3.124	-	Trifluoromethane, Fluoroform	1.2	118.76	2.4487
78	Freon 114	C ₂ Cl ₂ F ₄	0.2327	4	6.986	-	7.626	-	1,2-dichloro, 1,1,,2,2-tetrafluoroethane	1.2	48.65	3.1174
79	Furan	C ₄ H ₄ O	0.3889	4	2.783	-	3.037	-	Oxacylopentadiene	1.2	122.139	2.0253
80	Helium	He	1.4005	1	0.164	-	0.179	-	NA	1.66	2077.28	0.2304
81	Heptafluoropropane	C ₃ HF ₇	0.1987	4	6.950	-	7.586	-	Freon 227, R-227ea	1.2	48.90	2.9681
82	Hexamethyldisilazane	C ₆ H ₁₉ NSi ₂	0.1224	4	6.597	-	7.201	-	HMDS	1.2	51.52	3.2710
83	Hexamethyldisiloxane	C ₆ H ₁₈ OSi ₂	0.1224	4	6.637	-	7.245	-	NA	1.2	51.20	3.2794
84	Hexane	C ₆ H ₁₄	0.1828	4	3.522	-	3.845	-	NA	1.2	96.48	2.1062
85	Hexafluorobenzene	C ₆ F ₆	0.1733	4	7.605	-	8.301	-	Perfluorobenzene	1.2	44.69	3.0771
86	Hexene	C ₆ H ₁₂	0.1918	4	3.440	-	3.755	-	1-Hexene, 4-Methyl, 1-Pentene	1.2	98.79	2.0677
87	Hydrazine	N ₂ H ₄	0.5506	4	1.310	-	1.430	-	NA	1.2	259.46	1.1757
88	Hydrogen	H ₂	1.0038	1	0.082	-	0.090	-	NA	1.38	4124.51	0.3895
89	Hydrogen Bromide	HBr	1.0028	4	3.307	-	3.610	-	NA	1.38	102.76	7.6975
90	Hydrogen Chloride	HCl	1.0034	4	1.490	-	1.627	-	NA	1.4	228.04	1.5183
91	Hydrogen Cyanide	CHN	0.7772	4	1.105	-	1.206	-	Hydrocyanic Acid	1.2	307.66	1.0003
92	Hydrogen Fluoride	HF	1.0039	4	0.818	-	0.893	-	NA	1.4	415.59	0.6845
93	Hydrogen Iodide	HI	0.9996	4	5.228	-	5.707	-	NA	1.4	65.00	1.0000
94	Hydrogen Selenide	H ₂ Se	0.8412	5	3.309	-	3.612	-	NA	1.2	102.68	5.1920
95	Hydrogen Sulfide	H ₂ S	0.8420	4	1.393	-	1.521	-	NA	1.2	243.96	1.3174
96	Isobutane	C ₄ H ₁₀	0.2725	2	2.376	-	2.593	-	2-Methylpropane	1.2	143.05	1.6912
97	Isobutanol	C ₄ H ₁₀ O	0.2391	4	3.030	-	3.307	-	2-methyl-1-propanol, Isobutyl Alcohol	1.2	112.17	1.9228
98	Isobutene	C ₄ H ₈	0.2984	4	2.293	-	2.503	-	Isobutylene, Methylpropene	1.2	148.19	1.6663

99	Isopentane	C ₅ H ₁₂	0.2175	4	2.949	-	3.219	-	2-methylbutane	1.2	115.24	1.8975
100	Isopropyl Alcohol	C ₃ H ₈ O	0.2931	4	2.456	-	2.681	-	2- propanol	1.2	138.356	1.7335
101	Isoxazole	C ₃ H ₃ NO	0.4333	4	2.823	-	3.081	-	1-Oxa-2-azacyclopentadiene	1.2	120.39	2.1501
102	Ketene	C ₂ H ₂ O	0.5732	4	1.718	-	1.875	-	NA	1.2	197.79	1.5127
103	Krypton	Kr	1.4042	4	3.425	-	3.739	-	NA	1.6	99.22	1.0000
104	Methane	CH ₄	0.7787	1	0.656	-	0.716	-	NA	1.31	518.28	0.6105
105	Methanol	CH ₄ O	0.6167	4	1.310	-	1.430	-	Methyl Alcohol	1.2	259.49	1.1818
106	Methyl Acetate	C ₃ H ₆ O ₂	0.3083	4	3.028	-	3.305	-	Methyl Ethanoate	1.2	112.24	1.9967
107	Methyl Acetylene	C ₃ H ₄	0.4430	4	1.638	-	1.787	-	Propyne	1.2	207.53	1.3847
108	Methylamine	CH ₅ N	0.5360	4	1.269	-	1.386	-	Methanamine	1.2	267.72	1.1449
109	Methyl Bromide	CH ₃ Br	0.6358	4	3.881	-	4.236	-	NA	1.2	87.58	4.3841
110	Methyl Chloride	CH ₃ Cl	0.6639	4	2.064	-	2.253	-	Chloromethane	1.2	164.77	1.9480
111	Methylcyclohexane	C ₇ H ₁₄	0.1853	4	4.013	-	4.381	-	NA	1.2	84.681	2.2334
112	Methyl Ethyl Amine	C ₃ H ₉ N	0.2692	4	2.416	-	2.637	-	2-propanamine	1.2	140.661	1.7065
113	Methyl Ethyl Ether	C ₃ H ₈ O	0.2844	4	2.456	-	2.681	-	Methoxyethane	1.2	138.356	1.7285
114	Methyl Ethyl Sulfide	C ₃ H ₈ S	0.2743	4	3.113	-	3.398	-	2-thiabutane, Methylthioethane	1.2	109.169	1.9816
115	Methyl Fluoride	CH ₃ F	0.7247	4	1.391	-	1.518	-	Fluoromethane	1.2	244.31	1.2790
116	Methyl Formate	C ₂ H ₄ O ₂	0.3975	4	2.455	-	2.679	-	Acetic Acid	1.2	188.74	1.8491
117	Methyl Iodide	CH ₃ I	0.6514	4	5.802	-	6.333	-	NA	1.2	58.58	10.2105
118	Methyl Mercaptan	CH ₄ S	0.5409	4	1.966	-	2.146	-	Methanethiol	1.2	172.83	1.6930
119	Methylpentene	C ₆ H ₁₂	0.2037	4	3.440	-	3.755	-	NA	1.2	98.79	2.0555
120	Methyl Vinyl Ether	C ₃ H ₆ O	0.3435	4	2.374	-	2.591	-	NA	1.2	143.16	1.7377
121	Neon	Ne	1.4043	4	0.825	-	0.900	-	NA	1.6	412.02	0.6173
122	Nitric Oxide	NO	0.9795	4	1.226	-	1.339	-	Niutrogen Monoxide	1.4	277.09	1.1430
123	Nitrogen	N ₂	1.0000	1	1.145	-	1.250	-	NA	1.40	296.80	1.0434
124	Nitrogen Dioxide	NO ₂	0.7604	4	1.880	-	2.053	-	NA	1.2	180.73	1.8624
125	Nitrogen Tetroxide	N ₂ O ₄	0.3395	4	3.761	-	4.105	-	NA	1.2	90.36	2.4128
126	Nitrogen Trifluoride	NF ₃	0.5406	5	2.902	-	3.168	-	NA	1.2	117.10	2.5277
127	Nitromethane	CH ₃ NO ₂	0.4653	4	2.495	-	2.723	-	NA	1.2	136.21	1.9912
128	Nitrosyl Chloride	NOCl	0.6357	4	2.676	-	2.920	-	NA	1.2	127.02	2.6013
129	Nitrous Oxide	N ₂ O	0.7121	1	1.799	-	1.964	-	NA	1.2	188.91	1.7098
130	n-Pentane	C ₅ H ₁₂	0.2121	4	2.949	-	3.219	-	Dimethylpropane	1.2	115.24	1.9008
131	Octane	C ₈ H ₁₈	0.1386	4	4.669	-	5.096	-	NA	1.2	72.788	2.6119
132	Oxygen	O ₂	0.9779	1	1.308	-	1.428	-	NA	1.48	259.84	1.2483
133	Oxygen Difluoride	F ₂ O	0.6454	4	2.207	-	2.409	-	NA	1.2	153.983	2.0766
134	Ozone	O ₃	0.7022	4	1.962	-	2.141	-	NA	1.2	173.23	1.8868
135	Pentaborane	B ₅ H ₉	0.1499	5	2.580	-	2.816	-	NA	1.2	131.71	1.9855
136	Pentane	C ₅ H ₁₂	0.2175	4	2.949	-	3.219	-	NA	1.2	115.24	1.8975
137	Perchloryl Fluoride	ClFO ₃	0.4155	4	4.188	-	4.571	-	NA	1.2	81.16	3.0075
138	Perfluorocyclobutane	C ₄ F ₈	0.1711	4	8.176	-	8.924	-	Octafluorocyclobutane	1.2	41.57	3.1946
139	Perfluoroethane	C ₂ F ₆	0.2530	4	5.641	-	6.158	-	R116, Hexafluoroethane	1.2	60.24	2.8112
140	Perfluoropropane	C ₃ F ₈	0.1818	4	7.685	-	8.389	-	NA	1.2	44.22	3.0998
141	Phenol	C ₆ H ₆ O	0.2489	4	3.847	-	4.199	-	Hydroxybenzene	1.2	88.348	2.2089
142	Phosgene	COCl ₂	0.4812	4	4.043	-	4.413	-	Carbonyl Chloride	1.2	84.06	3.3063
143	Phosphine	PH ₃	0.7859	5	1.390	-	1.517	-	NA	1.2	244.56	1.2956
144	Phosphorus Trifluoride	PF ₃	0.4973	5	3.596	-	3.925	-	NA	1.2	94.52	2.9936
145	Propane	C ₃ H ₈	0.3499	1	1.802	-	1.967	-	NA	1.13	188.56	1.4516
146	Propyl Alcohol	C ₃ H ₈ O	0.3061	4	2.456	-	2.681	-	1- propanol	1.2	138.356	1.7427
147	Propyl Amine	C ₃ H ₉ N	0.2860	4	2.416	-	2.637	-	1-propanamine	1.2	140.661	1.7126
148	Propylene	C ₃ H ₆	0.4048	2	1.720	-	1.877	-	Propene	1.2	197.59	1.4223
149	Pyradine	C ₅ H ₅ N	0.3222	4	3.233	-	3.529	-	Azine, Azabenzene	1.2	105.114	2.1151
150	R32	CH ₂ F ₂	0.6197	2	2.126	-	2.321	-	Difluoromethane, Methylene Fluoride	1.2	153.91	1.9458
151	R123	C ₂ HCl ₂ F ₃	0.2583	2	6.251	-	6.823	-	1,1-Dichloro-2,2,2- trifluoroethane	1.2	54.37	3.0368

152	R123A	$C_2HCl_2F_3$	0.2699	4	6.251	-	6.823	-	1,2-Dichloro-1,2,2-trifluoroethane	1.2	54.37	3.1065
153	R125	C_2HF_5	0.2826	2	4.906	-	5.355	-	Pentafluoroethane	1.2	66.50	2.6844
154	R134	$C_2H_2F_4$	0.2996	4	4.170	-	4.552	-	1,1,2,2-tetrafluoroethane	1.2	78.42	2.4595
155	R134A	$C_2H_2F_4$	0.3110	2	4.170	-	4.552	-	1,1,1,2-tetrafluoroethane	1.2	78.42	2.5001
156	R143	$C_2H_3F_3$	0.3451	4	3.435	-	3.750	-	1,1,2-trifluoroethane	1.2	95.52	2.2693
157	R143A	$C_2H_3F_3$	0.3394	4	3.435	-	3.750	-	1,1,1-trifluoroethane, Methylfluoroform	1.2	95.52	2.2533
158	R152A	$C_2H_4F_2$	0.3877	4	2.700	-	2.947	-	1,1-Difluoroethane	1.2	122.18	1.9753
159	R218	C_3F_8	0.1818	4	7.685	-	8.389	-	Octafluoropropane	1.2	44.22	3.0998
160	R1416	$C_2H_3Cl_2F$	0.3047	4	4.780	-	5.218	-	1,1-Dichloro-1-fluoroethane,	1.2	71.10	2.7342
161	Radon	Rn	1.4043	4	9.074	-	9.905	-	NA	1.2	37.45	1.0000
162	Sec-butanol	$C_4H_{10}O$	0.2327	4	3.030	-	3.307	-	2-butanol, Sec-butyl Alcohol	1.2	112.17	1.9213
163	Silane	SiH_4	0.6809	5	1.313	-	1.433	-	NA	1.2	258.88	1.1934
164	Silicone Tetrafluoride	SiF_4	0.3896	5	4.254	-	4.644	-	Tetrafluorosilane	1.2	79.89	2.9041
165	Sulfur Dioxide	SO_2	0.6878	4	2.619	-	2.858	-	NA	1.2	129.78	2.7013
166	Sulfur Hexafluoride	SF_6	0.2701	1	5.970	-	6.516	-	NA	1.2	56.93	3.0092
167	Sulfur Tetrafluoride	SF_4	0.3752	4	4.417	-	4.821	-	NA	1.2	76.94	2.9215
168	Sulfur Trifluoride	SF_3	0.4368	4	3.640	-	3.974	-	NA	1.2	93.36	2.7312
169	Sulfur Trioxide	SO_3	0.5397	4	3.273	-	3.572	-	NA	1.2	103.85	2.8922
170	Tetrachloroethylene	C_2Cl_4	0.2926	4	6.778	-	7.399	-	NA	1.2	50.14	3.4711
171	Tetrafluoroethylene	C_2F_4	0.3395	4	4.088	-	4.462	-	Tetrafluoroethene	1.2	83.13	2.5732
172	Tetrahydrofuran	C_4H_8O	0.3271	4	2.947	-	3.217	-	NA	1.2	115.31	1.9924
173	Tert-butanol	$C_4H_{10}O$	0.2298	4	3.030	-	3.307	-	2-methyl-2-propanol, Tertiary Butyl Alcohol	1.2	112.17	1.9210
174	Thiophene	C_4H_4S	0.3538	4	2.783	-	3.037	-	Thiofuran	1.2	122.14	1.9586
175	Toluene	C_7H_8	0.2448	4	3.766	-	4.111	-	Methylbutene	1.2	90.24	2.1756
176	Transbutene	C_4H_8	0.2053	4	2.293	-	2.503	-	2-butene	1.2	148.19	1.6978
177	Trichloroethane	$C_2H_3Cl_3$	0.3133	4	5.453	-	5.952	-	NA	1.2	62.33	3.0712
178	Trichloroethylene	C_2HCl_3	0.3423	4	6.820	-	7.444	-	NA	1.2	63.28	3.9903
179	Trichlorotrifluoroethane	$C_2Cl_3F_3$	0.2253	4	7.659	-	8.360	-	R113, 1,1,2-trichloro-1,2,2-trifluoroethane UN 1296, n,n-diethylethanamine	1.2	44.374	3.2607
180	Triethylamine	$C_6H_{15}N$	0.1619	4	4.136	-	4.515	-	NA	1.2	82.167	2.3280
181	Trimethyl Amine	C_3H_9N	0.2822	4	2.416	-	2.637	-	n,n-dimethylmethanamine	1.2	140.661	1.7109
182	Tungsten Hexafluoride	WF_6	0.2453	5	12.174	-	13.288	-	NA	1.2	27.92	4.7379
183	Uranium Hexafluoride	UF_6	0.1859	4	14.389	-	15.706	-	Uranium Fluoride	1.2	23.62	4.4681
184	Vinyl Bromide	C_2H_3Br	0.4768	4	4.372	-	4.772	-	NA	1.2	77.74	3.5770
185	Vinyl Chloride	C_2H_3Cl	0.4956	4	2.555	-	2.788	-	Chloroethylene	1.2	133.04	2.0988
186	Vinyl Fluoride	C_2H_3F	0.5716	5	1.882	-	2.054	-	NA	1.2	180.58	1.6528
187	Water Vapor	H_2O	0.7992	5	0.742	-	0.810	-	NA	1.33	461.53	0.6715
188	Xenon	Xe	1.4042	4	5.366	-	5.858	-	NA	1.6	63.33	1.0000
189	Xylene, m-	C_8H_{10}	0.2036	4	4.339	-	4.737	-	NA	1.2	78.32	2.3103
190	Xylene, o-	C_8H_{10}	0.1953	4	4.339	-	4.737	-	NA	1.2	78.32	2.3108
191	Xylene, p-	C_8H_{10}	0.2028	4	4.339	-	4.737	-	NA	1.2	78.32	2.3102

6. WARRANTY

6.1. Warranty Repair Policy

Hastings Instruments warrants this product for a period of one year from the date of shipment to be free from defects in material and workmanship. This warranty does not apply to defects or failures resulting from unauthorized modification, misuse or mishandling of the product. This warranty does not apply to batteries or other expendable parts, or to damage caused by leaking batteries or any similar occurrence. This warranty does not apply to any instrument which has had a tamper seal removed or broken.

This warranty is in lieu of all other warranties, expressed or implied, including any implied warranty as to fitness for a particular use. Hastings Instruments shall not be liable for any indirect or consequential damages.

Hastings Instruments, will, at its option, repair, replace or refund the selling price of the product if Hastings Instruments determines, in good faith, that it is defective in materials or workmanship during the warranty period. Defective instruments should be returned to Hastings Instruments, **shipment prepaid**, together with a written statement of the problem and a Return Material Authorization (RMA) number.

Please consult the factory for your RMA number before returning any product for repair. Collect freight will not be accepted.

6.2. Non-Warranty Repair Policy

Any product returned for a non-warranty repair must be accompanied by a purchase order, RMA form and a written description of the problem with the instrument. If the repair cost is higher, you will be contacted for authorization before we proceed with any repairs. If you then choose not to have the product repaired, a minimum will be charged to cover the processing and inspection. Please consult the factory for your RMA number before returning any product repair.

TELEDYNE HASTINGS INSTRUMENTS
804 NEWCOMBE AVENUE
HAMPTON, VIRGINIA 23669 U.S.A.
ATTENTION: REPAIR DEPARTMENT

TELEPHONE (757) 723-6531
TOLL FREE 1-800-950-2468
FAX (757) 723-3925
E MAIL hastings_instruments@teledyne.com
INTERNET ADDRESS <http://www.teledyne-hi.com>

Repair Forms may be obtained from the "Information Request" section of the Hastings Instruments web site.

7. Drawings

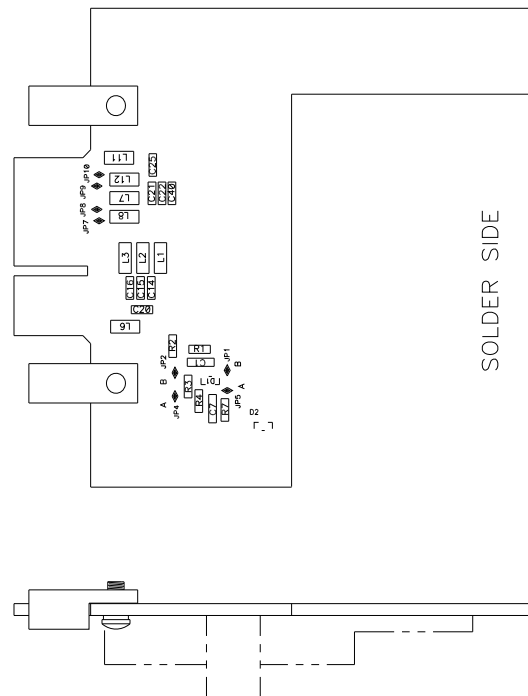

7.1. Notes:

1. Place jumper (Item 42) on pins 4 and 5 of P2 and P3 as shown.
2. Place one on bottom two pins (1 and 2) of JP3.
3. Place one on both pins of JP6.

JUMPERS TABLE		
10 SCCM	CLOSE JP1, JP2, (B) OPEN JP4, JP5	
>10 SCCM	CLOSE JP4, JP5, (A) OPEN JP1, JP2	STANDARD CONFIGURATION
PINS 2, B, C, ALL COMMON	CLOSE JP7, JP8, JP9, JP10	STANDARD CONFIGURATION
B= VALVE RETURN C= CIRCUIT COMMON	CLOSE JP8, JP10, OPEN JP7, JP9	
C= VALVE RETURN B= CIRCUIT COMMON	CLOSE JP7, JP9, OPEN JP8, JP10	

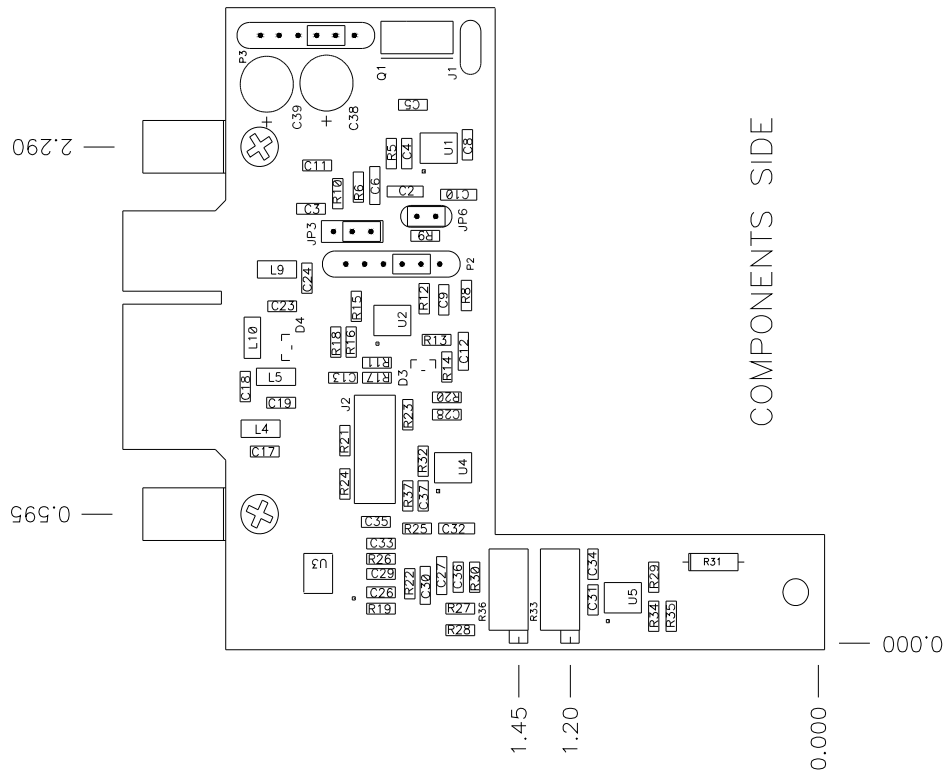

45	2	EXT TOOTH LOCKWASHER #4, SS	28-16-006	
44	2	SCREW 4-40 X .25 PH PAN SS	28-16-004	
43	2	PC BOARD SUPPORT STUD	35-01-125	
42	4	JUMPER, .025 SQ .100 CT	16-20-057	
41	1	CAP,0.18 uF,SMT-1206	11-08-144	C12
40	1	IC, AD822	56-02-102	U2
39	1	RES, 499K, SMT-0805	18-04-013	R8
38	1	RES, 357K, SMT-0805	18-04-012	R30
37	1	RES, 332K, SMT-0805	18-04-011	R7
36	1	RES, 182K, SMT-0805	18-04-010	R37
35	1	RES, 150K, SMT-0805	18-04-009	R4
34	1	RES, 49.9K, SMT-0805	18-04-018	R10
33	3	RES, 20K, SMT-0805	18-04-008	R15,R27,R28
32	1	RES, 11.8K, SMT-0805	18-04-007	R32
31	2	RES,2.87K, SMT-0805	18-04-006	R16,R29
30	4	RES, 243, SMT-0805	18-04-005	R12,R20,R23,R34
29	4	RES, 2M, SMT-0805	18-04-017	R1,R9,R11,R17
28	2	RES, 1.5M, SMT-0805	18-04-016	R3,R22
27	3	RES, 1M, SMT-0805	18-04-004	R19,R25,R26
26	4	RES, 100K, SMT-0805	18-04-003	R5,R6,R13,R35
25	2	RES, 10K, SMT-0805	18-04-002	R2,R14
24	2	RES, 1K, SMT-0805	18-04-001	R21,R24
23	1	RES, 100, SMT-0805	18-04-015	R18
22	1	IC, LM317LM	56-02-129	U5
21	1	CAP, 2.2 uF, SMT-1206	11-08-151	C2
20	6	CAP, 1.0 uF, SMT-1206	11-08-146	C6,C7,C10,C27,C30,C32
19	1	CAP, 0.47 uF, SMT-1206	11-08-152	C1
18	22	CAP, 0.1 uF, SMT-0805	11-08-147	C5,C8,C14-C26,C28,C29,C31,C33-C35,C40
17	1	CAP, 0.047 uF, SMT-0805	11-08-150	C4
16	5	CAP, .01 uF, SMT-0805	11-08-149	C3,C9,C11,C13,C37
15	1	CAP, 0.001 uF, SMT-0805	11-08-148	C36
14	1	POT, 5K 3296Z	19-05-070	R33
13	1	POT, 500K 3296Z	19-05-082	R36
12	1	TRANSISTOR, 2N4920	51-03-030	Q1
11	1	DIODE, BAV99ZXCT	36-01-053	D1
10	3	DIODE, BAS-21	36-01-054	D2,D3,D4
9	1	IC, OP-177FS,PREC.	56-02-111	U3
8	2	IC, AD706JR	56-02-105	U1,U4
7	0.25	SOCKET, 5-PIN FEMALE	16-20-046	J2
6	1	PC-888 BARE PCB	26-04-888B	31524
5	0.5	MALE SIP-PIN	16-20-053	JP3,JP6,P2,P3
4	1	TEMPSTOR, 1.2K	40-01-011	R31
3	12	INDUCTOR, 100uH, SMT	17-01-066	L1-L11,L12
2	.056	CONNECTOR, 2 PIN RT. ANGLE	16-52-001	J1
1	2	CAP, 22uF, 35V	11-03-173	C38,C39
ITEM	QTY	NAME	MATERIAL	NOTE
PARTS LIST				

CONTROLLER CIRCUIT

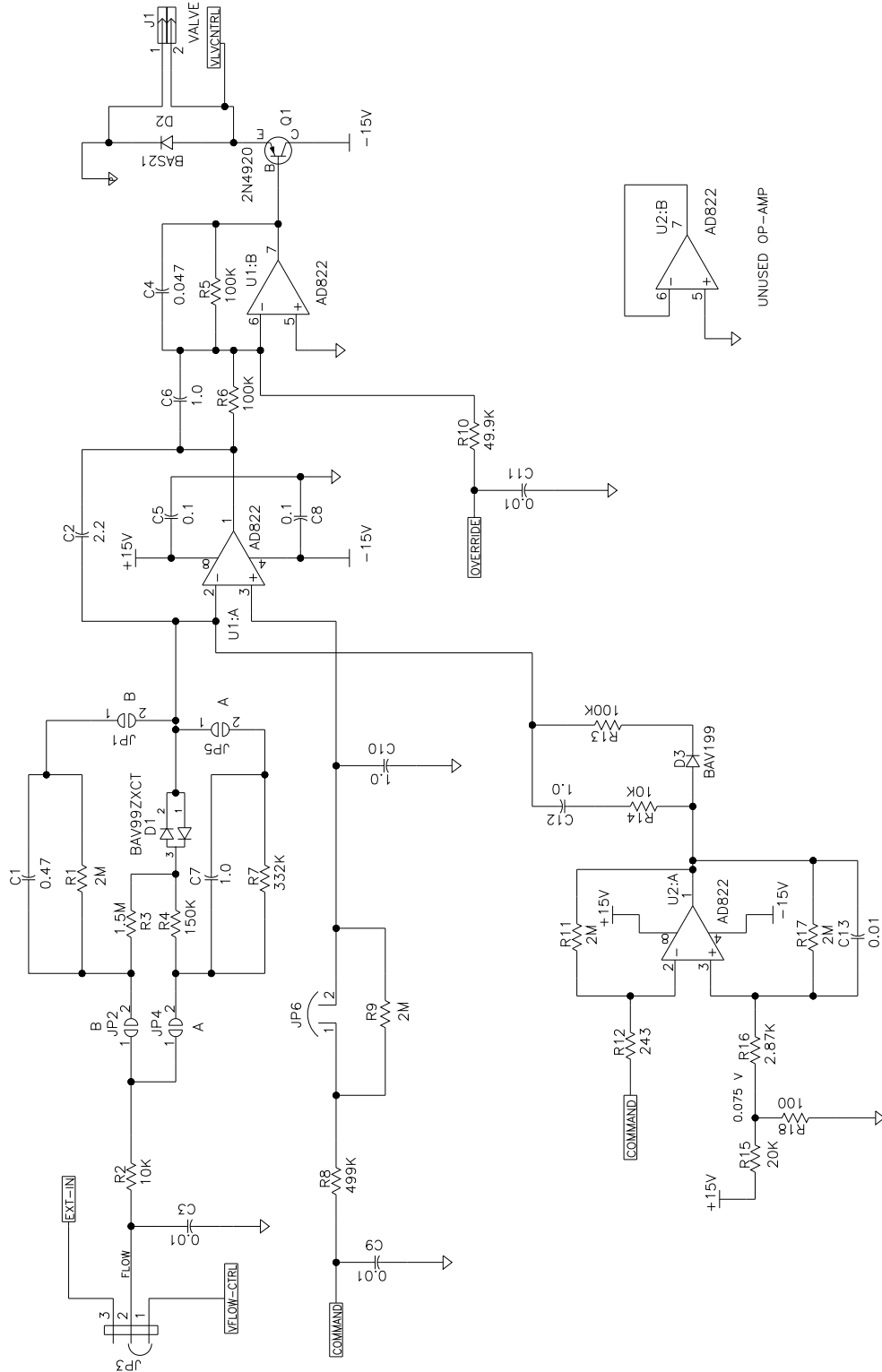

AUTO SHUT-OFF CIRCUIT

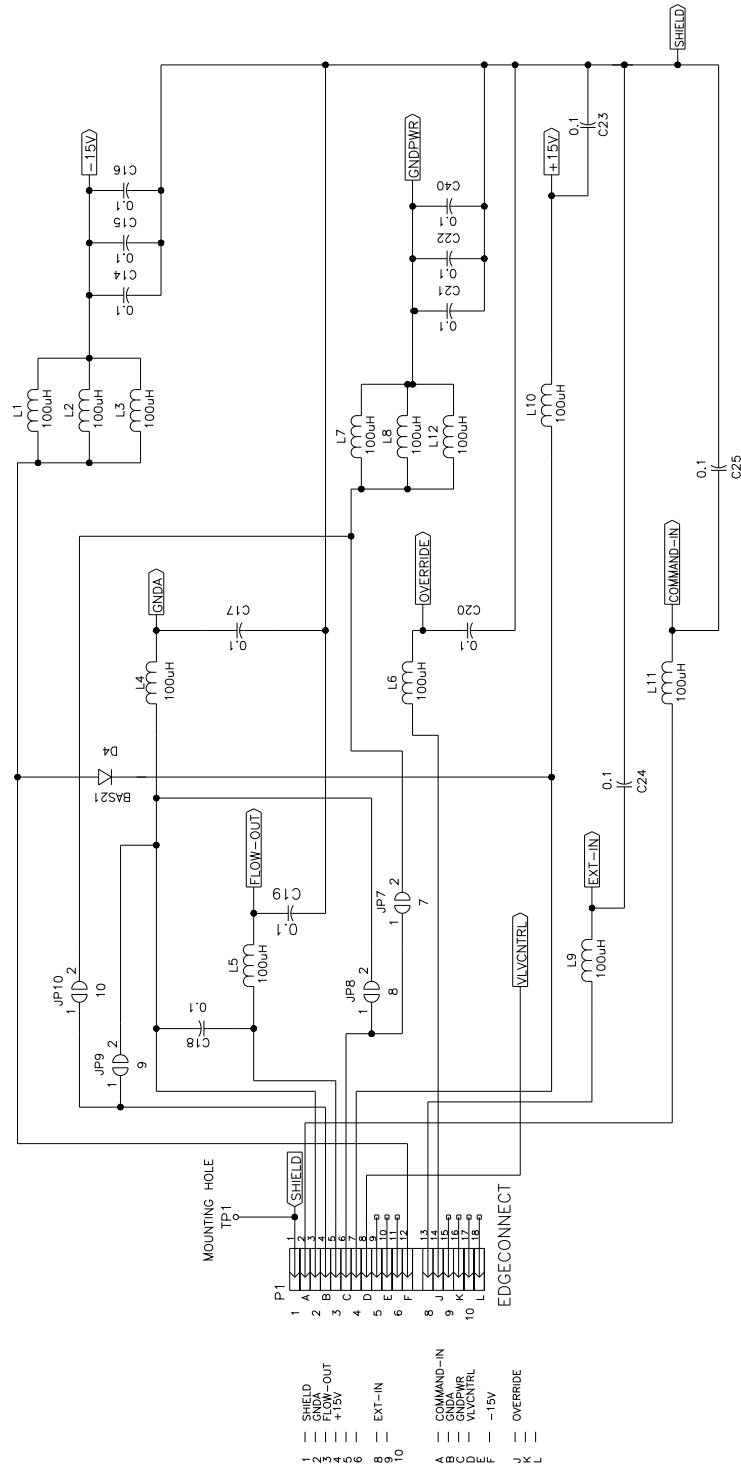

FILTER CIRCUITS
EDGE CONNECTOR CONTROLLER

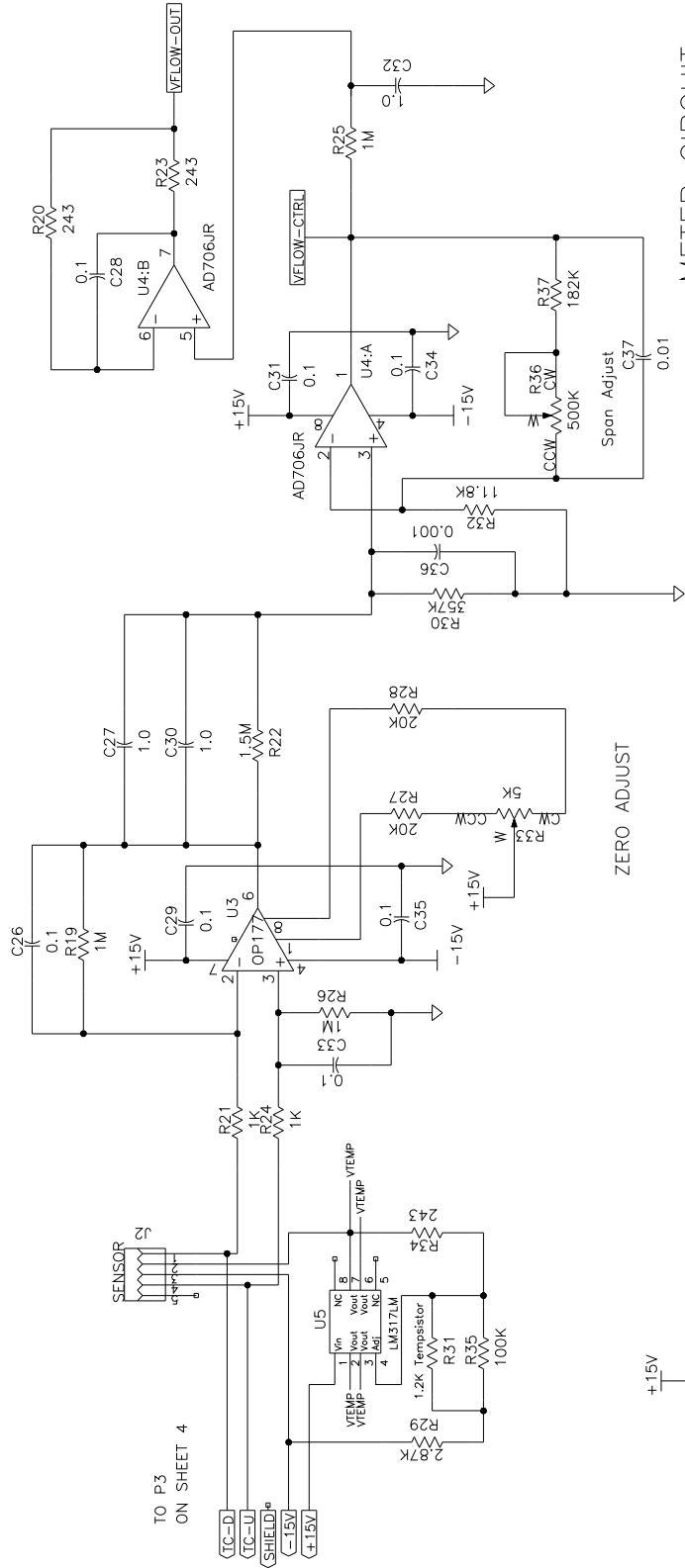

ZERO ADJUST

METER CIRCUIT

