

TELEDYNE HASTINGS INSTRUMENTS



INSTRUCTION MANUAL

200/202 SERIES FLOWMETERS/CONTROLLERS



Manual Print History

The print history shown below lists the printing dates of all revisions and addenda created for this manual. The revision level letter increases alphabetically as the manual undergoes subsequent updates. Addenda, which are released between revisions, contain important change information that the user should incorporate immediately into the manual. Addenda are numbered sequentially. When a new revision is created, all addenda associated with the previous revision of the manual are incorporated into the new revision of the manual. Each new revision includes a revised copy of this print history page.

Revision A (Document Number 140-0999)	September 1999
Revision B (Document Number 140-1199).....	November 1999
Revision C (Document Number 140-102002)	October 2002
Revision D (Document Number 140-082005).....	August 2005
Revision E (Document Number 140-112007).....	November 2007
Revision F (Document Number 140-062008).....	June 2008
Revision G (Document Number 140-082008).....	August 2008
Revision H (Document Number 140-022009).....	February 2009
Revision J (Document Number 140-102009).....	October 2009



Visit www.teledyne-hi.com for WEEE disposal guidance.



CAUTION: The instruments described in this manual are available with multiple pin-outs. Ensure that all electrical connections are correct.



CAUTION: The instruments described in this manual are designed for INDOOR use only.



CAUTION: The instruments described in this manual are designed for Class 2 installations in accordance with IPC standards

Hastings Instruments reserves the right to change or modify the design of its equipment without any obligation to provide notification of change or intent to change.

Table of Contents

1. GENERAL INFORMATION.....	4
1.1. FEATURES	4
1.2. SPECIFICATIONS HFM-200	4
1.3. SPECIFICATIONS HFC-202	5
1.4. OPTIONAL 4-20 MA CURRENT OUTPUT	5
1.5. OTHER ACCESSORIES.....	6
1.5.1. Hastings Power supplies.....	6
1.5.2. Interconnecting Cables.....	6
2. INSTALLATION AND OPERATION.....	7
2.1. RECEIVING INSPECTION	7
2.2. POWER REQUIREMENTS	7
2.3. OUTPUT SIGNAL.....	7
2.4. MECHANICAL CONNECTIONS.....	7
2.4.1. Standard Configuration	7
2.4.2. LFE Configuration	8
2.5. ELECTRICAL CONNECTIONS	8
2.6. OPERATION	9
2.6.1. Operating Conditions	9
2.6.2. Zero Check	9
2.6.3. High Pressure Operation	10
2.6.4. Blending of Gases	10
2.7. OPERATION WITH EXTERNAL DEVICES	10
2.7.1. Operation with a Hastings power supply.....	10
2.7.2. Operation with a Power Supply other than a Hastings	11
2.7.3. Operation with an external sensor (Fig. 2.2)	11
2.7.4. Response to Command Changes	11
2.8. RANGE CHANGING.....	12
2.9. VALVE-OVERRIDE CONTROL.....	12
3. THEORY OF OPERATION	13
3.1. OVERALL FUNCTIONAL DESCRIPTION.....	13
3.2. SENSOR.....	13
3.3. ELECTRONICS	14
3.4. SHUNT	14
3.5. VALVE	15
4. MAINTENANCE.....	16
4.1. AUTHORIZED MAINTENANCE.....	16
4.2. TROUBLESHOOTING	16
4.3. ADJUSTMENTS	17
4.3.1. Calibration Procedure: (Figure 4.1).....	17
4.3.2. Miscellaneous adjustments.....	18
4.4. END CAP REMOVAL	18
4.5. PRINTED CIRCUIT BOARD REPLACEMENT.....	18
4.6. SENSOR REPLACEMENT	18
4.7. ORIFICE CHANGES	18
5. WARRANTY AND REPAIR	20
5.1. WARRANTY REPAIR POLICY	20
5.2. NON-WARRANTY REPAIR POLICY	20

1. General Information

The Hastings HFM-200 mass flow meter and HFC-202 flow controller are designed to accurately measure and control mass flow over the range of 10 sccm to 30 slm, without corrections or compensations for gas pressure and temperature with an accuracy of better than $\pm 1\%$ FS. Hastings mass flow instruments do not require any periodic maintenance under normal operating conditions with clean gases. No damage will occur from the use of moderate overpressures (~ 500 psi/3.45MPa) or overflows. Instruments are normally calibrated with the appropriate standard calibration gas (nitrogen) then a correction factor is used to adjust the output for the intended gas.

1.1. Features

- **LINEAR BY DESIGN.** The HFM-200/HFC-202 series is inherently linear (no linearization circuitry is employed). Should recalibration in the field be desired (a calibration standard is required), the customer needs to simply set the zero and span points. There will be no appreciable linearity change of the instrument when the flowing gas is changed.
- **MODULAR SENSOR.** The HFM-200/HFC-202 series incorporates a removable/replaceable sensor module. Field repairs to units can be achieved with a minimum of production line downtime.
- **METER SETTLING TIME.** Changes in flow rate for the HFM-200 are detected in less than 2 seconds when using the fast-response circuitry.
- **LOW TEMPERATURE DRIFT.** The temperature coefficient of span for the HFM-200/HFC-202 series is typically less than 0.05% of full scale/ $^{\circ}\text{C}$ from 0-60 $^{\circ}\text{C}$. The temperature coefficient of zero is typically less than 0.035 % of reading/ $^{\circ}\text{C}$ from 0-60 $^{\circ}\text{C}$.
- **CURRENT LOOP.** The 4-20 mA option gives the user the advantages of a current loop output to minimize environmental noise pickup.

1.2. Specifications HFM-200

Accuracy ¹ and Linearity	$\pm 1\%$ F.S.
Repeatability	$\pm 0.05\%$ F.S.
Standard Pressure Rating	500 psig
Pressure Coefficient.....	-0.0067%/psi (0-1000 psig N ₂) typical
High-Pressure Option	Proof tested to 1500 psig
Leak Integrity	$< 1 \times 10^{-9}$ sccs
Temperature Coefficient	Zero $\pm 0.035\%$ FS/ $^{\circ}\text{C}$ (0-60 $^{\circ}\text{C}$) Span $\pm 0.05\%$ RDG/ $^{\circ}\text{C}$ (0-60 $^{\circ}\text{C}$)
STP	0 $^{\circ}\text{C}$ and 760 Torr
Power	± 15 VDC @ ± 25 mA
Flow Signal	(inherently linear) 0-5.00 VDC or 4-20 mA
Wetted Material ²	316 SS, Viton®, 82/18 Au/Ni Braze, Trace Silver Solder
Connector	15-pin subminiature D
Fittings	1/4-in. Swagelok®, others available
Weight (approx.)	1.8 lb (0.82 kg)

1.3. SPECIFICATIONS HFC-202

Accuracy ¹ and Linearity	±1% F.S.
Repeatability	±0.05% F.S.
Std. Pressure Rating	500 psig
High Pressure Option	Proof tested to 1500 psig
Pressure Coefficient	-0.0067%/psi (0-1000 psig N ₂) typical
Control Valve DP*	per customer order
Leak Integrity	< 1x10 ⁻⁹ sccs
Temperature Coefficient	Zero ±0.035% FS/°C (0-60°C) Span ±0.05% RDG/°C (0-60°C)
STP	0°C and 760 Torr
Power	±15 VDC @ +60 mA/-185 mA
Flow Signal	(inherently linear) 0-5.00 VDC or 4-20 mA
Command Signal	0-5.00 VDC or 4-20 mA
Wetted Material ²	316 SS, 302 SS, Nickel, Viton, 82/18 Au/Ni Braze, Trace Silver Solder, Kalrez®
Connector	15-pin subminiature D
Fittings	1/4-in. Swagelok, others available
Weight (approx.)	1.8 lb (0.82 kg)

1 Stated accuracy is for nitrogen or other gas specific calibration and use with this gas only.

2 Other materials are available. Viton is the standard O-ring option.

* Specifications may vary for instruments with ranges greater than 10 SLM.

1.4. Optional 4-20 mA Current Output

An option to the standard 0-5 VDC output is the 4-20 mA current output that is proportional to flow. The 4 - 20 mA signal is produced from the 0 - 5 VDC output of the flow meter. The current loop output is useful for remote applications where pickup noise could substantially affect the stability of the voltage output.

The current loop signal replaces the voltage output on pin 6 of the “D” connector. The current loop may be returned to either the power supply common or the -15 VDC connections on the power supply. If the current loop is returned to the power supply common, the load must be between 0 and 600 Ohm. If it is returned to the -15VDC, the load must be between 600 and 1200 Ohm. Failure to meet these conditions will cause failure of the loop transmitter.

The 4-20 mA I/O option can accept a current input. The 0-5 VDC command signal on pin 14 can be replaced by a 4-20mA command signal. The loop presents an impedance of 75 Ohms and is returned to the power supply through the valve common.

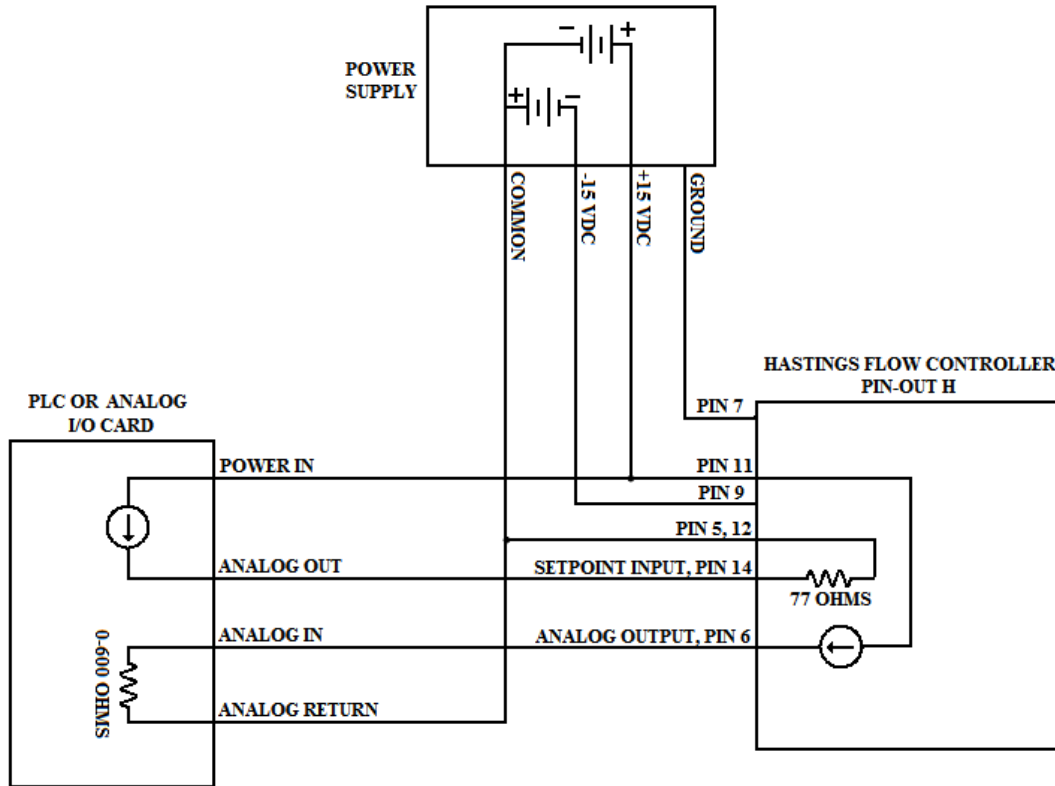

1.5. Other Accessories

1.5.1. Hastings Power supplies

Hastings Power Pod power supply/display units are available in one and four channel versions. They convert 100, 115 or 230VAC to the ± 15 VDC required to operate the flow meter and provide a digital indication of the flow rate. Interface terminals for the retransmission of the flow meter analog output signal are located on the rear of the panel.

The Power Pod 100 and 400 models are built with controllers in mind but will work with meters as well. The Model 40 is for flow meters only. Throughout this manual, when reference is made to a power supply, it is assumed the customer is using a Hastings power supply. Hastings PowerPod-100 and PowerPod-400 power supplies are CE marked, but the Model 40 does not meet CE standards at this time. The Model 40 and PowerPod-100 are not compatible with 4–20 mA analog signals. With the PowerPod 400, individual channels' input signals, as well as their commands, become 4–20 mA compatible when selected. The PowerPod-400 also sports a Totalizer feature. More information about the Power Pods can be found on the Hastings web site. <http://www.teledyne-hi.com/products/powerpod-series.htm>

1.5.2. Interconnecting Cables

Cables are available from Hastings, in various lengths, to connect from the 15 pin "D" connector on the back of the Power Pod directly to any of the 200 series and 300 series flow instruments (including digital versions). More information about the available cables can be found in the Power Pod 400 bulletin on the Hastings web site. <http://www.teledyne-hi.com/pdfs/bulletins.htm>

2. Installation and Operation

This section contains the steps necessary to install a new flow meter/controller into operation as quickly and easily as possible. Please read the following thoroughly before attempting to install the instrument.

2.1. Receiving Inspection

Carefully unpack the Hastings HFM-200/HFC-202 series instrument and any accessories that have also been ordered. Inspect for any obvious signs of damage to the shipment. Immediately advise the carrier who delivered the shipment if any damage is suspected. Check each component shipped with the packing list. Insure that all parts are present (i.e., Flowmeter, power supply, cables, etc.). Optional equipment or accessories will be listed separately on the packing list. There may also be one or more OPT-options on the packing list. These normally refer to special ranges or special gas calibrations. They may also refer to special helium leak tests, or high pressure tests. In most cases, these are not separate parts, but special options or modifications built into the flow meter.

2.2. Power Requirements

The HFM-200/HFC-202 series requires ± 15 VDC @ ± 25 mA (HFM-200) +60 mA, -185 mA (HFC-202) for proper operation. The supply voltage should be sufficiently regulated to no more than 50 mV ripple. The supply voltage can vary from 14.0 to 16.0 VDC. Surge suppressors are recommended to prevent power spikes reaching the instrument. The Hastings power supplies described in Section 1.4.1 satisfy these power requirements.

The HFM-200/HFC-202 series instruments have an integral 5 VDC reference source. This stable voltage is on pin 15 of the “D” connector and may be used for the command voltage.

2.3. Output Signal

The standard output of the flow meter is a 0-5 VDC signal proportional to the flow rate. In the Hastings power supplies, the output is routed to the display and is also available at the terminals on the rear panel. If a Hastings supply is not used, the output is available on pin 6 of the “D” connector and is referenced to pin 5. It is recommended that the load resistance be no less than $2k\Omega$. If the optional 4-20 mA output is used, the load impedance must be selected in accordance with Section 1.3.

2.4. Mechanical Connections

2.4.1. Standard Configuration

The flow meter may be mounted in any position as long as the direction of gas flow through the instrument follows the arrow marked on the bottom of the flow meter case label. The preferred orientation is with the inlet and outlet fittings in a horizontal plane (if operating with a dense gas or at high pressures the instrument must be installed horizontally). When mounted in a different orientation the instrument should be re-zeroed at zero flow with the system pressurized to the expected operating pressure.

The smallest of the internal passageways in the HFM-200/HFC-202 series is the diameter of the sensor tube, which is 0.0125” (0.31 mm), so the instrument requires adequate filtering of the gas supply to prevent blockage or clogging of the tube.

The pressure regulator and the plumbing upstream must be of sufficient size to minimize changes in the upstream pressure. When switching from full flow to zero flow, the inlet pressure of the instrument should rise to no more than 30% above the inlet pressure at full flow. In general, high capacity regulators and large internal diameter plumbing help to make the system more stable. The pressure drop between the regulator and the instrument due to line resistance should be minimized. The differential pressure

across a meter should be less than 6" of H₂O at maximum flow. Controllers may have much higher differential pressures depending upon the size of the installed orifice.

There are two 8-32 threaded holes, located on the bottom of the base that can be used to secure it to a mounting bracket, if desired (screws provided). Other holes for special mounting can be added to the end cap as desired.

The standard inlet and outlet fittings for the 200/202 are 0.25" and 0.125" Swagelok (optional VCR or VCO fittings). The O-rings for the end cap and the sensor are Viton (optional Kalrez or Neoprene). It is suggested that all connections be checked for leaks after installation. This can be done by pressurizing the instrument (do not exceed 500 psig unless the Flowmeter is specifically rated for higher pressures) and applying a diluted soap solution to the flow connections.

2.4.2. LFE Configuration

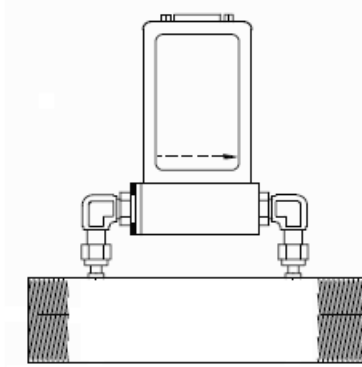

The installation of a Laminar Flow Element (LFE) in a flow circuit requires sufficient conductance before entering and after exiting the LFE sensor taps to allow the flow to fully develop with a minimum of turbulence. This provides the best conditions for accurate sampling of the flow by the sensor branch (See Theory of Operation). Please note that, for laminar flow elements whose diameter is less than 3", the inlet and outlet taps of the sensor circuit are 1.5" from the ends of an 8" LFE. Laminar flow elements whose diameter is 3" or greater, have inlets and outlets sensor taps 2.5" from the ends of a 10" LFE. These distances may be taken into account and treated as part of the following rule-of-thumb:

- 1) an upstream flow tube length of 5 times, or greater, the diameter of the selected LFE before the sensor inlet tap.
- 2) a downstream tube length of 1 time, or greater, the diameter of the selected LFE after the sensor inlet tap.

EXAMPLE:

Suppose a 4" LFE is selected. The length of 4" diameter tubing or pipe, upstream of the sensor inlet tap, will be a minimum of 20". The minimum length of 4" tubing or pipe downstream from the sensor outlet tap will be 4". The length of additional 4" inlet tubing required for the 4" LFE is $20" - 2.5" = 17.5"$. The additional length of 4" tubing required for the outlet side of the 4" LFE is $4" - 2.5" = 1.5"$. This brings the overall length of the assembly to 19".

Tubular configurations upstream or downstream that involve conical shapes or optimized expansion nozzles will reduce the length of tubing required for flow straightening, but the actual length necessary will be a function of that geometrical shape. Testing of that configuration will be necessary for each application. The same is true for screen meshes or flow straighteners.

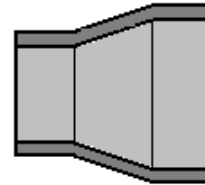

2.5. Electrical Connections

If a power supply from Hastings Instruments is used, installation consists of connecting the HFM-200/HFC-202 series cable (#AF-8AM) from the "D" connector on the rear of the power supply to the "D" connector on the top of the flow meter. If a different power supply is used, follow the instructions below when connecting the flow meter.

Connecting the HFM-200/HFC-202 series flow meters with anything other the prescribed cables and power supplies discussed above, can severely damage the instrument and void the warranty. Figure 2.1 shows the schematic layout for connecting the instrument to an appropriate power supply.

The power supply used must be capable of supplying +15VDC at 50mA and -15VDC at -200mA for each controller. These voltages must be referenced to a common ground. Connect -15VDC to pin 9 and +15VDC to pin 11. Pins 5 and 12 are both commons and they must be connected together and to the ground connection at the power supply. Do not connect them together at the flow controller as the resulting crosstalk could result in flow instabilities. Pin 7 is the case ground. It should be connected to the cable shield if available and to the AC ground to the power supply.

Pin 6 is the output signal from the flow controller. This output will be 0-5VDC, 5VDC being 100% of rated or full flow. Pin 14 is the command input. This should be a 0-5VDC signal and must be free of spikes or other electrical noise, as these will generate false flow commands that the controller would attempt to flow. Pin 15 is a regulated +5.00VDC output reference that is normally adjusted to 5.01VDC so that the user can achieve full scale command set point. The reference is designed to provide the command signal for pin 14 by connecting one end of a potentiometer to pin 15 and the other end to ground. The center lead would then be connected to pin 14.

If a valve override switch is not desired, the unit is ready for use at this time. If the override switch is desired, connect the center pin of a single pole, three-position switch with the center off position to pin 8. Connect +15VDC to one end of the switch, and -15VDC to the other end. This will result in the valve being full open when +15VDC is supplied to pin 8, off when -15VDC is supplied and auto-control when there is no connection to pin 8 (OPEN-AUTO-CLOSE). This setup will be adequate for most purposes, but there will be a small delay for capacitors to charge between switch operation and control override.

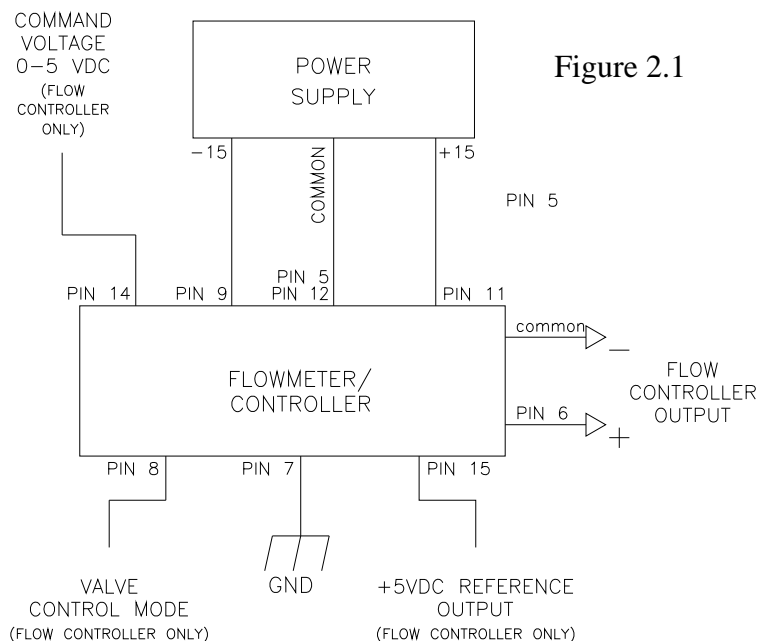

Figure 2.1

2.6. Operation

The standard instrument output is a 0 - 5 VDC out and the signal is proportional to the flow i.e., 0 Volts = zero flow and 5 Volts = 100% of rated flow. The 4 - 20 mA option is also proportional to flow, 4 mA = zero flow and 20 mA = 100% of rated flow. It is suggested that all connections be checked for leaks after installation. This can be done by pressurizing the instrument (do not exceed 500 psig unless the instrument is specifically rated for higher pressures) and applying a diluted soap solution to the connections.

2.6.1. Operating Conditions

For proper operation, the combination of ambient temperature and gas temperature must be such that the flow meter temperature remains between 0 and 50°C. The most accurate measurement of flow will be obtained if the flow meter is zeroed at operating temperature as temperature shifts result in some zero offset. The HFM-201/HFC-203 series is intended for use in non-condensing environments only. Condensate or any other liquids which enter the flow meter may destroy its electronic components.

2.6.2. Zero Check

Turn the power supply on if not already energized. Allow for a 1 hour warm-up. Stop all flow through the instrument and wait 2 minutes. Caution: Do not assume that all metering valves completely shut off

the flow. Even a slight leakage will cause an indication on the meter and an apparent zero shift. For the standard 0-5 VDC output, adjust the zero potentiometer located on the lower outlet side of the flow meter until the meter indicates zero. For the optional 4-20 mA output, adjust the zero potentiometer so that the meter indicates slightly more than 4 mA, i.e. 4.03 to 4.05 mA. This slight positive adjustment ensures that the 4-20 mA current loop transmitter is not in the cut-off region. The error induced by this adjustment is approximately 0.3% of full scale. This zero should be checked periodically during normal operation. Zero adjustment is required if there is a change in ambient temperature, or vertical orientation of the flow meter/controller.

2.6.3. High Pressure Operation

When operating at high pressure, the increased density of gas will cause natural convection to flow through the sensor tube if the instrument is not mounted in a level position. This natural convection flow will be proportional to the system pressure. This will be seen as a shift in the zero flow output that is directly proportional to the system pressure.

2.6.4. Blending of Gases

In the blending of two gases, it is possible to maintain a fixed ratio of one gas to another. In this case, the output of one flow controller is used as the reference voltage for the set point potentiometer of a second flow controller. The set point potentiometer then provides a control signal that is proportional to the output signal of the first flow controller, and hence, controls the flow rate of the second gas as a percentage of the flow rate of the first gas.

EXAMPLE: Flow controller A has 0-100 slpm range with a 5.00 Volt output at full scale. Flow controller B has 0-10 slpm range with a 5.00 Volt output at full scale. If flow controller A is set at 80 slpm, its output voltage would be 4.00 Volts ($80 \text{ slpm}/100 \text{ slpm} \times 5.00 \text{ Volts} = 4.00 \text{ Volts}$). If the output signal from flow controller A is connected to the command potentiometer of flow controller B, it then becomes a variable reference voltage for flow controller B proportional to the flow rate of flow controller A.

If the set point potentiometer of flow controller B is set at 50% of full scale, and the reference voltage from flow controller A is 4.00, then the command signal going to flow controller B would be 2.00 Volts ($4.00 \text{ Volts} \times 50.0\% = 2.00 \text{ Volts}$). The flow of gas through flow controller B is then controlled at 4 slpm ($2.00 \text{ Volts}/5.00 \text{ Volts} \times 10 \text{ slpm} = 4 \text{ slpm}$).

The ratio of the two gases is 20:1 (80 slpm/4slpm). The % mixture of gas A is 95.2 (80slpm/84slpm) and the % mixture of gas B is 4.8% (4 slpm/84 slpm).

Should the flow of flow controller A drop to 78 slpm, flow controller B would drop to 3.9 slpm, hence maintaining the same ratio of the mixture. ($78 \text{ slpm}/100\text{slpm} \times 5\text{v} = 3.90\text{v} \times 50\% = 1.95\text{v}$; $1.95\text{v}/5.00\text{v} \times 10 \text{ slpm} = 3.9 \text{ slpm}$; $78 \text{ slpm}: 3.9 \text{ slpm} = 20:1$)

2.7. Operation with External Devices

2.7.1. Operation with a Hastings power supply.

There are two controls for each flow controller connected to a Hastings power supply. A switch labeled "OPEN; AUTO; CLOSED" (valve over ride THPS 400 only) and a potentiometer labeled "COMMAND". For normal operation, the valve over ride switch will be in the "AUTO" position. The "CLOSE" position removes all power from the valve, shutting off flow regardless of the command pot setting. The "OPEN" position applies full available valve voltage to the valve, causing it to open, regardless of the command pot setting. The "OPEN" position is useful for purging systems. It is recommended that the valve over ride switch not be left in this position for extended periods of time, with no flow through the controller, as a small positive zero shift may be observed.

The "COMMAND" pot adjusts the Analog command signal sent to the flow controller. The setting for each controller connected to the power supply can be observed. (Depending on how the power supply was set up, the display could indicate in flow units or percent of full scale).

Hastings Power Supply Feature Guide			
Feature	Model 40	Power Pod 100	Power Pod 400
Digital Readout	✓	✓	✓
± 15 Volts	✓	✓	✓
Analog Outputs	✓	✓	✓
Controller		✓	✓
Analog Control	✓		
Front Panel Override	✓		✓
Totalizer			✓
4 -20 mA	✓		✓
Ratio Control			✓
Alarms	✓	✓	✓
Multi-Channel Display			✓
Conversion Factors	✓	✓	✓

2.7.2. Operation with a Power Supply other than a Hastings

The flow controller must be connected to the power source as specified in section 2.6. In general, a 0-5 VDC command signal proportional to the intended flow (0 Volts = zero flow; 5 Volts = 100% of rated flow) must be applied to pin 14 of the “D” connector. A 0-5 VDC signal proportional to the flow rate through the instrument will be present on pin 6 of the “D” connector. The control mode is selected via pin 8 of the “D” connector. Apply +15 Volts for full open, -15 Volts for closed and allow pin 8 to float for flow proportional to the command voltage. Refer to your power supply manual for the specifics of implementing these parameters.

2.7.3. Operation with an external sensor (Fig. 2.2)

In some instances, it might be desirable to use an external sensor to provide process information to the control circuitry in the flow controller. For example, you might want to control the pressure in a vacuum system by adjusting the rate at which the system is backfilled with a gas. The new, enhanced HFC series of flow controllers have provision for accepting a 0-5VDC output from an external sensor at pin 13 of the “D” connector. To activate this feature, the cover of the HFC must be removed to gain access to PC-828 and move a jumper on JP1. JP1 is a three pin jumper block located just below the “D” connector. In the normal operating mode, the jumper covers the bottom two pins. To select “External Sensor”, move the jumper to the upper two pins. This swaps the flow input to the controller circuit from the flow meter output to pin 13 of the “D” connector.

2.7.4. Response to Command Changes

The response of the control circuit to changes to the command signal is set at the factory for fast, stable response. Should it be necessary, the response is adjustable using the jumper labeled “JP4,” located in the center of PC-828.

The fastest response to command changes is obtained when JP4 is covered by the jumper. This setup allows large overshoot and undershoot swings in the actual flow rate while the control circuit is

establishing control at the new command point. The slowest response to command changes is obtained when JP4 is not covered by a jumper. This setup results in no overshoot or undershoot in the actual flow rate as the controller circuit establishes control at the new command point.

To adjust the response, you need a means of producing a step change in the command voltage from 10% of full scale to 100% of full scale. Follow the steps outlined below:

- 1) Cover the pins of JP4 with a jumper. (see fig. 2.2)
- 2) Set the command voltage to 10% of full scale. Allow the flow to stabilize.
- 3) Step change the command voltage to 100%, and observe the flow through the controller. If the overshoot is too large, remove the jumper. Reset the command voltage to 10%, and allow the controller to stabilize.
- 4) To prevent loss of the unused jumper, place it over one pin only on JP4.

2.8. Range Changing

The range of the flow controller can be changed in the field if recalibration facilities are available. The flow controller may require a different orifice, which can be purchased separately from the factory. A listing of the orifices available and their flow rates can be found in Section 5.0. The instructions to change the flow range can be found in Section 4.6.

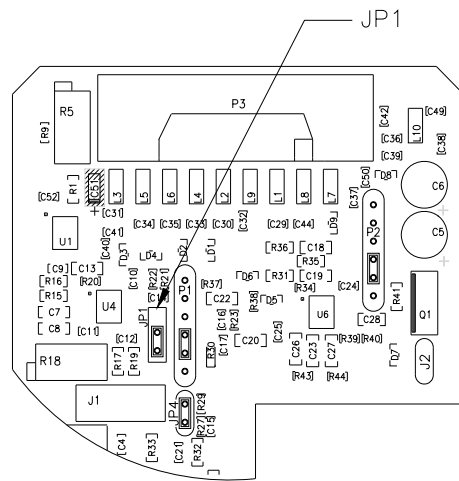

Fig. 2.2

2.9. Valve-Override

The valve override control line provides a method to override the loop controller and open or close the valve regardless of the flow or command signals. During normal operation this line must be allowed to float freely. This will allow the loop control to open and close the valve as it requires. If the valve override line is forced high ($> +5$ volts) the valve will be forced full open. If the valve-override line is forced negative (< -5 volts) the valve will be forced closed.

Control

3. Theory of Operation

This section contains a functional description of Hastings flow controllers. Detailed schematics and parts lists can be obtained by contacting Hastings using the contact information found at the end of this document. In this section and other sections throughout this manual, when a power supply is mentioned, it is assumed that the customer has a Hastings Power Supply. These sections are not applicable if another type of power supply is used.

3.1. Overall Functional Description

The Hastings flow controller consists of a sensor, electronic circuitry, a shunt and a valve. The sensor measures the flow rate from 0 to 10 sccm of the gas to be metered. The shunt divides the flow such that the flow through the sensor is a precise percentage of the flow through the shunt. The flow through the sensor and the shunt is always laminar. The circuit board amplifies the sensor output and uses this output to control the valve position. The valve is an automatic metering solenoid type; its height off the seat is controlled by the voltage in its coil. All of these components working together result in a fast, stable flow controller.

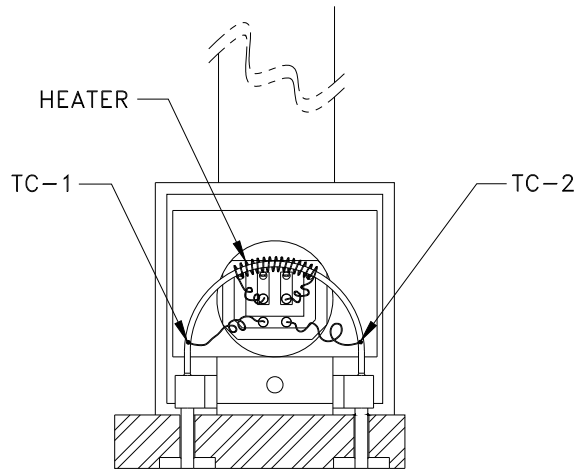

Figure 3.1

3.2. Sensor

The Hastings HFM-200/HFC-202 series operates on a unique thermal electric principle whereby a metallic capillary tube is heated uniformly by a resistance winding attached to the midpoint of the capillary (see Figure 3.1). Thermocouples TC-1 and TC-2 are welded at equal distances from the midpoint and develop equal outputs at zero flow.

When flow occurs through the tubing, heat is transferred from the tube to the gas on the inlet side, and from the gas back to the tube on the outlet side creating an asymmetrical temperature distribution (see Figure 3.2). The thermocouples sense this decrease and increase in the capillary tube temperature and produce a millivolt output signal proportional to that change.

For a constant power input, the differential thermocouple output is a function of the mass flow rate and the heat capacity of the gas. Since the heat capacity of many gases is

Figure 3.2

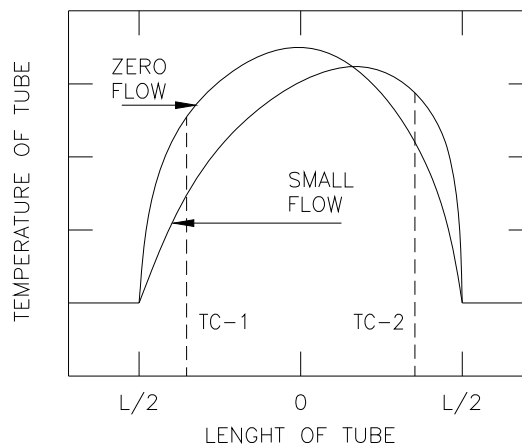

relatively constant over wide ranges of temperature and pressure, the flow meter may be calibrated directly in mass units for those gases. Changes in gas composition usually only require application of a simple multiplier to the air calibration to account for the difference in heat capacity and thus the flow meter is capable of measuring a wide variety of gases. The HFM sensor measures approximately 10 sccm, full scale flow.

3.3. Electronics

The Hastings HFM-200/HFC-202 series uses a thermal flow sensor to measure through a capillary tube, which is a fixed percentage of the total flow through the instrument. This sensor develops an output signal proportional to flow which is approximately 1 mV full scale magnitude. This signal is amplified by the meter circuitry until it is 0-5.00 VDC. This 5 Volt output is sent back to the power supply and to the flow meter circuitry, if applicable. At the power supply the 5 Volt output is sent to the terminals on the back and to the decoding circuitry in the display which converts it to a 3-digit output.

The controller circuitry utilizes the command and the flow voltages as input signals. The 0-5VDC command signal is subtracted from the 0-5VDC flow signal creating an error signal. This signal is amplified and causes the solenoid valve to move. The amount and direction of the movement is dependent upon the value and the sign of the error signal, and tends to minimize the error signal.

3.4. Shunt

Measurement of flow rates higher than the 10 sccm full scale is achieved by dividing the flow with a fixed ratio shunting arrangement, as is illustrated in Figure 3.3. This is accomplished by placing the measuring capillary tube parallel with one or more dimensionally similar channels, called a laminar flow element (LFE). Therefore, the sensor only needs to heat the gas passing through the capillary tube resulting in low power requirements, while retaining all the mass measuring characteristics.

The HFM-200/HFC-202 series has two possible shunts. The low range shunt consists of tubes inserted into a cylindrical base. This shunt is adjustable for ranges from 0-10 sccm to 0-250 sccm (see Figure 3.4). The medium range shunt consists of a corrugated stainless steel ribbon wound into a coil and fused. It is adjustable from 0-0.25 slm to 0-25 slm ranges.

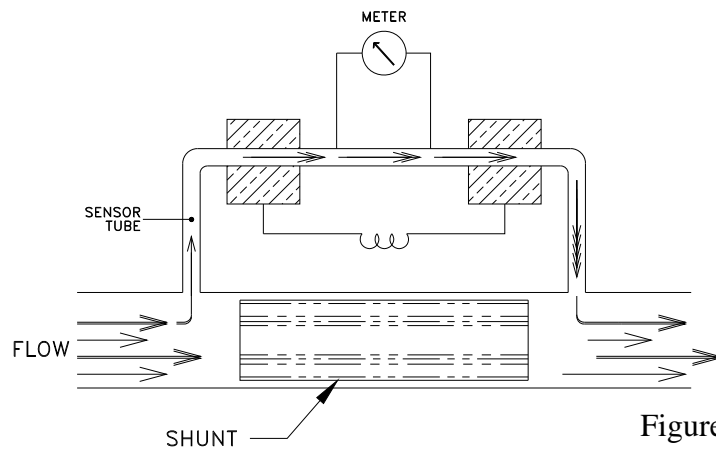

Figure 3.3

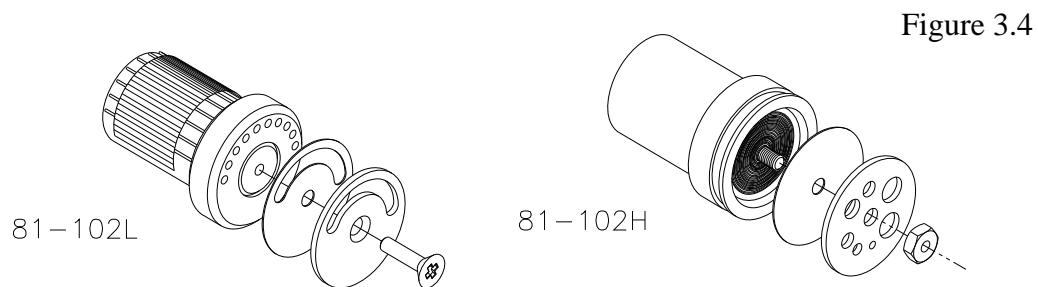

Figure 3.4

3.5. Valve

The control valve is an “automatic metering solenoid” valve. While most solenoids operate in either the fully open or fully closed state, the automatic metering solenoid valve is designed to control flow (see Figure 3.5). A spring, connected to the plunger assembly, holds a magnetic plunger tightly against an orifice to shut off flow. The magnetic plunger is surrounded by an electrical coil which, when energized with electrical current, lifts the plunger off the orifice and allows flow to pass between the orifice and the plunger seat. Controlling the current through the coil controls the distance between the orifice and the plunger seat, effectively controlling the flow through the valve. This current is controlled by a feedback loop that matches the transducer output with the command voltage.

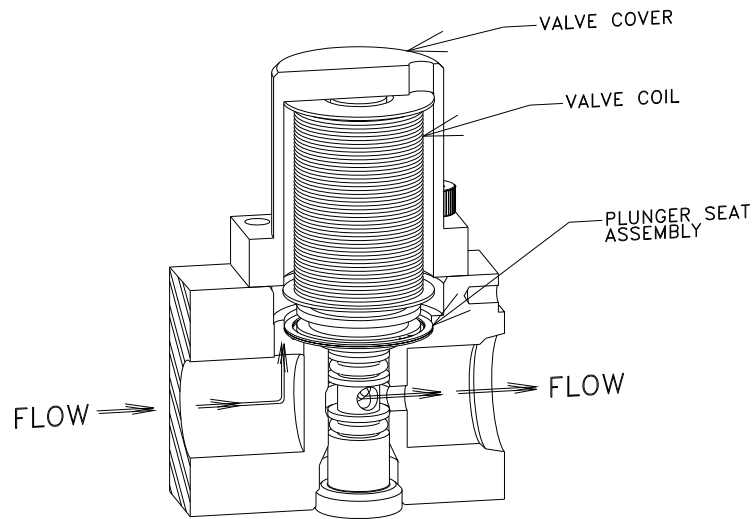

Figure 3.5

4. Maintenance

This section contains service and calibration information. Some portions of the instrument are delicate. Use extreme care when servicing the flow controller.

4.1. Authorized Maintenance

With proper care in installation and use, the flow controller will require little or no maintenance. If maintenance does become necessary, most of the instrument can be cleaned or repaired in the field. Some procedures may require recalibration. Do not attempt these procedures unless facilities are available. Entry into the sensor or tampering with the printed circuit board will void the warranty. Do not perform repairs on these assemblies while unit is still under warranty.

4.2. Troubleshooting

SYMPTOM: Override CLOSE function is enabled but flow remains or 0.00 VDC is commanded and flow remains.

CAUSE: Orifice out of adjustment or faulty op-amp

ACTION: Check the valve voltage between pins TP-2 & TP-12 on the 15-pin D-connector. If the voltage is less than 3.00 VDC, then turn the orifice clockwise until flow stops. If the voltage is greater than 3.00 VDC, replace U6; if less, replace transistor Q1.

SYMPTOM: Output of unit is proportional to flow but extremely small and not correctable by span pot.

CAUSE: Sensor is not being heated.

ACTION: Unplug connector J1. Check the following resistance: The resistance between pins 2 & 3 of the sensor should be approximately 2500 Ohms (see Figure 3.1 on page 8). The resistance between pins 1 & 4 should be approximately 2.3 Ohms. The resistance between pins 2 & 3 and the base of the sensor should be essentially infinite. If not, replace the sensor unit. If sensor reads O.K., check the voltage output on pins 2 & 3 of the jack in the board. If it does not read approximately 22 VDC then replace regulator U2.

SYMPTOM: Sensor has proper resistance readings, but little or no output with flow.

CAUSE: Plugged sensor.

ACTION: Shut off gas supply and power supply. Remove cover and PC board from unit. Remove sensor assembly and examine. If sensor has evidence of plugging, clean or replace as applicable

SYMPTOM: Flow controller oscillates.

CAUSE: Flow controller not adjusted for the dynamics of the flow system.

ACTION: Check upstream and downstream pressures. The gas supply regulator should not have excessive lockup when flow shuts off. Also ensure that there is not a large drop in pressure between the regulator and the instrument due to line resistance. Oscillations can also be caused if a large flow restriction is pneumatically close to the downstream end of the flow controller. The differential pressure across the unit must be between 10-50 psig.

SYMPTOM: Little or no flow, even with Valve Override OPEN enabled.

CAUSE: Plugged orifice.

ACTION: Verify the presence of a 10-50 psig pressure across the instrument. If present, shut off gas supply and power supply. Remove orifice per Section 4.9. Examine orifice. If plugged, clean or replace as applicable. Reassemble valve.

SYMPTOM: Flow meter reads other than 0.00 VDC with no flow, or there is a small flow when flow meter reads 0.00 VDC.

CAUSE: ZERO potentiometer is out of adjustment.

ACTION: Shut off all flow. Adjust ZERO potentiometer until output reads 0.00 VDC.

SYMPTOM: Flow meter out of calibration and nonlinear.

CAUSE: Leaks in gas inlet or outlet fittings.

ACTION: Check all fittings for leaks by placing soap solution on all fittings between gas supply and final destination of gas. Check flow meter for leaks. Replace "O" rings if required or recalibrate as necessary.

4.3. ADJUSTMENTS

4.3.1. Calibration Procedure: (Figure 4.1)

- 5) NOTE: Steps 5 and 6, adjusting the SPAN pot and performing a calibration run, will require the use of a calibration reference.
- 1) Connect power cable to D connector as specified in Section 2.7. Allow instrument to warm up for 30 minutes with 10% flow and instrument in AUTO position.
- 2) After the warm up period, set the flow to zero and insure that, indeed, there is zero flow. Wait for 2 minutes.
- 3) Set ZERO (R13) potentiometer for 0.000 VDC output.
- 4) Turn on gas supply to inlet of instrument. Use the Valve Override CLOSE feature or, if Valve Override is unavailable, give the controller a command of zero. Adjust the orifice underneath the controller to obtain zero flow. If the Valve Override feature was used to close the valve, set it to AUTO. Ensure that full range flow can still be obtained at minimum inlet pressure.
- 5) NOTE: Perform this step only if a calibrated flow reference is available. Set command to 100%. Adjust SPAN (R18) pot until the flow reference reads full scale flow (5.000 VDC).
- 6) Record flow meter and flow reference outputs for flow rates of 20%, 40%, 60%, 80% and 100%.

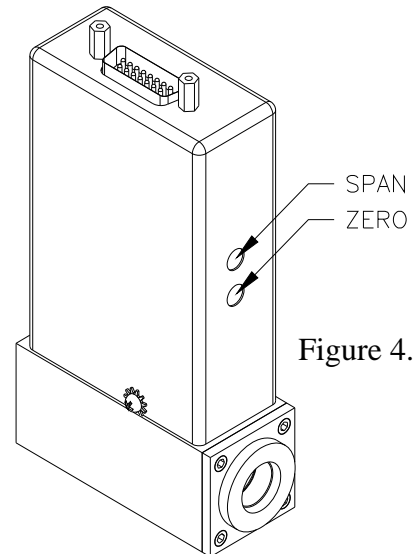

Figure 4.1

4.3.2. Miscellaneous adjustments

Periodically, during normal operation, the ZERO should be checked and adjusted when required. If the instrument is not shutting completely off when the Valve Override CLOSE function is active, or a command of zero flow has been given, then the orifice may require approximately 1/8 turn clockwise.

4.4. End Cap Removal

The end cap on the inlet side must be removed to gain access to the filter or shunt assembly. First shut off the supply of gas to the instrument. Disconnect the Swagelok fitting on the inlet and outlet sides of the transducer, and remove it from the system plumbing. Remove the four hex bolts holding the end cap to the instrument (see Figure 4.1). Carefully remove the end cap, filter, wave spring (if present) and shunt, noting their order and proper orientation. The shunt can be severely damaged if dropped. Examine the filter and shunt. If either is dirty or blocked, clean or replace as applicable. Reassembly is the reverse of the removal procedure. Recalibration of the HFC is necessary.

4.5. Printed Circuit Board Replacement

In the unlikely event that the PC board fails, it is easily removed from the instrument and replaced with a spare to minimize instrument downtime. Replacement of the PC board will require the instrument to be recalibrated per Section 4.3.1.

Unplug the power cable from the top of the transducer. Remove the two jackscrews next to the "D" connector and the two screws on the sides of the cover. Lift off the cover and unplug the four-wire sensor plug and the two wire valve plug, noting their orientation prior to removal.

Remove the screw that holds the PC board to the sensor. Troubleshoot or replace as applicable. Installation is the reverse of the above procedure. Recalibrate if any components were changed or if any potentiometers were adjusted.

4.6. Sensor Replacement

If the sensor fails or becomes plugged it can be removed. Remove the cover and the PC board per Section 4.5 above. Remove the three bolts holding the sensor to the instrument base. Remove the sensor from the base noting the two O-rings (Parker 2-005, V884-75) between the sensor and the base. If the sensor is plugged it can be cleaned by running a fine wire (approximately 0.008" diameter) through the tube. If sensor needs replacement, obtain another from the factory and install it. Ensure that O-rings are clean and intact. Install O-rings on seating surface, then carefully place sensor over O-rings and tighten down the three screws evenly. Replacement of sensor will require recalibration per Section 4.3.1.

4.7. Orifice Changes

The orifice may require replacement if a flow range change is desired, if a large change in differential pressures across the valve is desired or in the event that a small orifice becomes plugged. Replacement orifices can be acquired from the factory having a Cv in the range of 0.0000263 to 0.129.

To change the orifice in the HFC-202 series, turn the instrument upside-down and turn the orifice counterclockwise until it stops coming out. Then grasp the exposed orifice end and pull it straight out. See Figure 4.2.

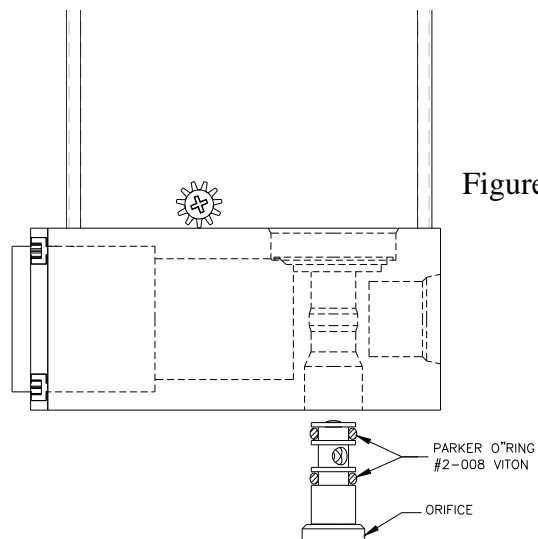

Figure 4.2

Prior to reinstallation of the orifice, inspect the two O-rings mounted on it for damage. Replace if cut or gouged.

Lubricate the O-rings slightly with a silicone based grease, and the threads with anti-galling compound. Push the orifice into its hole and screw it in until it is flush with the instrument base. Apply pressure to the inlet side of the instrument.

Enable the Valve Override CLOSE function or unplug the instrument. Screw the orifice in a few more turns until the flow through the instrument stops, then turn it an additional 1/4 turn clockwise.

5. Warranty and Repair

5.1. Warranty Repair Policy

Hastings Instruments warrants this product for a period of one year from the date of shipment to be free from defects in material and workmanship. This warranty does not apply to defects or failures resulting from unauthorized modification, misuse or mishandling of the product. This warranty does not apply to batteries or other expendable parts, or to damage caused by leaking batteries or any similar occurrence. This warranty does not apply to any instrument which has had a tamper seal removed or broken.

This warranty is in lieu of all other warranties, expressed or implied, including any implied warranty as to fitness for a particular use. Hastings Instruments shall not be liable for any indirect or consequential damages.

Hastings Instruments, will, at its option, repair, replace or refund the selling price of the product if Hastings Instruments determines, in good faith, that it is defective in materials or workmanship during the warranty period. Defective instruments should be returned to Hastings Instruments, **shipment prepaid**, together with a written statement of the problem and a Return Material Authorization (RMA) number.

Please consult the factory for your RMA number before returning any product for repair. Collect freight will not be accepted.

5.2. Non-Warranty Repair Policy

Any product returned for a non-warranty repair must be accompanied by a purchase order, RMA form and a written description of the problem with the instrument. If the repair cost is higher, you will be contacted for authorization before we proceed with any repairs. If you then choose not to have the product repaired, a minimum will be charged to cover the processing and inspection. Please consult the factory for your RMA number before returning any product repair.

TELEDYNE HASTINGS INSTRUMENTS
804 NEWCOMBE AVENUE
HAMPTON, VIRGINIA 23669 U.S.A.
ATTENTION: REPAIR DEPARTMENT

TELEPHONE (757) 723-6531
TOLL FREE 1-800-950-2468
FAX (757) 723-3925
E MAIL hastings_instruments@teledyne.com
INTERNET ADDRESS <http://www.teledyne-hi.com>

Repair Forms may be obtained from the "Information Request" section of the Hastings Instruments web site.