

TELEDYNE HASTINGS INSTRUMENTS



INSTRUCTION MANUAL

HFM-D-300 / HFC-D-302
FLOWMETER/CONTROLLER



Manual Print History

The print history shown below lists the printing dates of all revisions and addenda created for this manual. The revision level letter increases alphabetically as the manual undergoes subsequent updates. Addenda, which are released between revisions, contain important change information that the user should incorporate immediately into the manual. Addenda are numbered sequentially. When a new revision is created, all addenda associated with the previous revision of the manual are incorporated into the new revision of the manual. Each new revision includes a revised copy of this print history page.

Revision A (Document Number 157-062008).....June 2008
Revision B (Document Number 157-092008).....September 2008
Revision C (Document Number 157-082009)August 2009
Revision D (Document Number 157-112009) November 2009



Visit www.teledyne-hi.com for WEEE disposal guidance.



CAUTION:

The instruments described in this manual are available with multiple pin-outs. Ensure that all electrical connections are correct.



CAUTION:

The instruments described in this manual are designed for INDOOR use only.



CAUTION:

The instruments described in this manual are designed for Class 2 installations in accordance with IAW/IPC standards

Hastings Instruments reserves the right to change or modify the design of its equipment without any obligation to provide notification of change or intent to change.

Table of Contents

1. GENERAL INFORMATION.....	4
1.1. FEATURES.....	4
1.2. SPECIFICATIONS.....	5
1.3. OTHER ACCESSORIES.....	6
2. INTRODUCTION.....	7
3. INSTALLATION & OPERATION.....	8
3.1. RECEIVING INSPECTION.....	8
3.2. POWER REQUIREMENTS.....	8
3.3. OUTPUT SIGNAL.....	8
3.4. QUICK START.....	8
4. SETUP.....	9
4.1. MECHANICAL CONNECTIONS.....	9
4.2. ELECTRICAL CONNECTIONS.....	9
5. DIGITAL COMMUNICATION.....	14
5.1. BASICS.....	14
5.2. OPERATING STATES.....	15
5.3. DIGITAL CONTROL.....	15
6. OPERATION.....	20
6.1. OPERATING CONDITIONS.....	20
6.2. ZERO CHECK.....	20
6.3. HIGH PRESSURE OPERATION.....	20
6.4. BLENDING OF GASES.....	22
6.5. CONTROLLING OTHER PROCESS VARIABLES.....	22
6.6. COMMAND INPUT.....	23
6.7. VALVE OVERRIDE CONTROL.....	23
7. THEORY OF OPERATION.....	24
7.1. OVERALL FUNCTIONAL DESCRIPTION.....	24
7.2. SENSOR DESCRIPTION.....	24
7.3. SENSOR THEORY.....	25
7.4. BASE.....	26
7.5. SHUNT DESCRIPTION.....	27
7.6. SHUNT THEORY.....	27
8. MAINTENANCE.....	32
8.1. AUTHORIZED MAINTENANCE.....	32
8.2. TROUBLESHOOTING.....	32
8.3. END CAP REMOVAL.....	36
9. VOLUMETRIC VS. MASS FLOW.....	37
10. GAS CONVERSION FACTORS.....	38
11. REFERENCES.....	40
12. WARRANTY AND REPAIR.....	41
12.1. WARRANTY REPAIR POLICY.....	41
12.2. NON-WARRANTY REPAIR POLICY.....	41

1. General Information

The Hastings mass flow meter (HFM-D-300) and controller (HFC-D-302) are intrinsically linear and are designed to accurately measure and control mass flow over the range of 5 sccm to 25 slm. Hastings mass flow instruments do not require any periodic maintenance under normal operating conditions with clean gases. No damage will occur from the use of moderate overpressures (~500 psi/3.45MPa) or overflows. Instruments are normally calibrated with the appropriate standard calibration gas (nitrogen) then a conversion factor is used to adjust the output for the intended gas. Calibrations for other gases, such as oxygen, helium and argon, are available through special order.

1.1. Features

- **LINEAR BY DESIGN.** The 300 series is intrinsically linear. The output of the sensor has a non-linearity less than 2% before the curve fit. This minimizes the density driven errors that occur when gases other than the calibration gas are measured.
- **CURVE FIT CORRECTION.** The Digital 300 series uses a curve fitting technique to remove any residual non-linearity from the system to improve the overall accuracy. This significantly improves the % of Reading errors when flow rates are at a small fraction of the controller's full scale flow.
- **FLEXIBLE POWER REQUIREMENTS.** The Digital 300 series can operate with any power supply capable of providing 15 -30 Vdc between the high and low supply pins. Bipolar ± 12 Vdc, ± 15 Vdc or unipolar 24 Vdc are all acceptable.
- **DIGITAL COMMUNICATIONS.** The Digital 300 series can communicate or be controlled via an RS232 port or a RS485 bus. Baud rates up to 19.2k baud are supported.
- **ANALOG EMULATION.** The Digital 300 series instrument can be set up to mimic an analog instrument. In this configuration the flow output is available as an analog signal and flow controllers will respond to analog commands.
- **AUTO-ZERO.** The Digital 300 series of flow controllers can re-zero automatically. This feature is enabled by default at the factory. Auto-zeroing will occur whenever the command signal is set to zero for more than 3 minutes. This feature removes most temperature driven zero shifts.
- **LOW DP.** The Digital 300 sensor requires a pressure of approximately 0.25 inches of water (62 Pa) at a flow rate of 10 sccm. The low pressure drop across this instrument is ideal for leak detection applications since the pneumatic settling times are proportional to the differential pressure.
- **LOW TEMPERATURE DRIFT.** The temperature coefficient of span for the Digital 300 series is less than 0.05% of Reading per °C. The temperature coefficient of zero is negligible when the auto-zero system is active.
- **METAL SEALS.** The Digital 300 Series is constructed of 316 SS. All internal seals are made with Ni 200 gaskets, eliminating the permeation, degradation and out gassing problems of elastomer O-rings.
- **LOW SURFACE AREA.** The shunt is designed to have minimal wetted surface area and no un-swept volumes. This will minimize particle generation, trapping and retention. Electro polished surfaces are available (4RA).
- **CURRENT LOOP.** The 0-20 mA or 4-20 mA option gives the user the advantages of a current loop output to minimize environmental noise pickup.
- **NO FOLDOVER.** The output signal is linear for very large over flows and is monotonically increasing thereafter. The output signal will not come back on scale when flows an order of magnitude over the full scale flow rate are measured. This means no false acceptable readings during leak testing.

1.2. Specifications

Accuracy	<±(0.2% full scale (F.S.) + 0.5% of reading)
Repeatability	±0.1% of F.S.
Maximum pressure	500 psi [3.45 MPa].
Maximum pressure	1000 psi [6.9 MPa] (with high pressure option)
Pressure coefficient	<0.01% of reading/psi [0.0015%/kPa] (N ₂)(0-50 psig) See pressure section for higher pressure errors.
Operating temperature	0-50°C in non-condensing environment
Temperature coefficient of zero	N/A for controller with Auto-zero < 0.2%/°C of Full Scale for meters
Temperature coefficient of span	maximum ±500 ppm/°C
Leak integrity	1x10 ⁻⁹ std. cc/s.
Standard flow ranges	5, 10, 20, 50, 100, 200, 500 sccm. 1, 2, 5, 10, 20, 30 slpm. (N ₂ Equivalent)
Standard output	0-5 VDC. (load min 2k Ohms)
Optional output	4 -20 & 0-20 mA, 0-10 VDC
Power requirements	±(15) VDC @ 55 mA (meters) ±(15) VDC @ 150 mA (controller) 15-30 VDC @ 5.5 watt (meter) Class 2 power 150VA max 7.5 watt (controller)
Wetted materials	316 stainless steel, nickel 200
Attitude sensitivity of zero	< ±0.7% F.S. for 90° before auto zero {N ₂ at 19.7 psia (135 KPa)}
Weight	1.93 lb [0.88 kg]
Electrical connector	15-pin subminiature “D”
Fitting options	¼” Swage, 1/8” Swage, VCR [®] , VCCO [®] , 9/16”-18 Female threads, Surface mount
Face seal to face seal length	1.88”(47.75 mm) VCR [®]

1.3. Other Accessories

1.3.1. Hastings Power Supplies

Hastings power supplies are available in one or four channel versions. They convert 100, 115 or 230VAC to the 15-30 VDC required to operate the flow meter. Interface terminals for the analog output signals are located on the rear of the panel. Throughout this manual, when reference is made to a power supply, it is assumed the customer is using a Hastings Instruments 100/400 supply. Hastings PowerPod-100 and PowerPod-400 power supplies are CE marked, but the Model 40 does not meet CE standards at this time. The Model 40 and PowerPod-100 are not compatible with 4–20 mA analog signals. With the PowerPod 400, individual channels' input signals, as well as their commands, become 4–20 mA compatible when selected. The PowerPod-400 also sports a Totalizer feature.

1.3.2. 300/302 Series Power Supply Interface Cables

The Digital 300 flow meters normally come with the standard “H” pin-out connector. This type of connector is supplied on the Hastings Instruments AF-8-AM cable with grey back shells. “U” pin-out versions of the 300 series instruments require a different cable to connect to the power supply. This cable is identifiable by its black back-shell and is available as Hastings Instrument P/N 65-791.

2. Introduction

The Digital 300 is an all-digital instrument that is based on the standard 300 series flow controller. This digital version uses the same base, flow shunting arrangement, and sensor as the analog 300 series. The sensor is operated in the same “constant temperature above ambient” manner as the analog 300 series. The valve is essentially the same except some metal has been removed from the sides of the orifices and pole pieces to make room for the cover. The coil cover has been modified to reduce the fringing magnetic fields. Mechanically the Digital 300 series has the same fitting, spacing and mounting-hole arrangements as the analog 300 series and, with consideration given for its additional height, could be a drop in replacement for improved control and flexibility.

The meter card and controller cards on the analog 300 have been replaced with a Main and an I/O board. These boards are higher than the analog versions but the Digital 300 series has the same 15-pin D connector as an analog 300 along with 2 digital connectors (RJ-11). The Digital 300 series will, normally, be setup at the factory to emulate an analog 300 unit. It will accept the same command signals and generate the same analog output signals.

Because the sensor and shunts are the same those used in the analog version of these instruments, the digital version starts with excellent linearity and stability. It then uses a precision A/D converter to supply digital readings. The product of the converted sensor current and voltage signals produces a digital power signal. This digital conversion accounts for the improved accuracy and stability over the analog version. A measure of the power signal at a known zero flow condition is stored in non-volatile storage and subtracted from the instantaneous power measurement to produce a signal proportional to the molar gas flow.

During initial calibration, the residual non-linearity is measured and a fifth order polynomial is fitted to the error signal. This fifth order polynomial is stored in non-volatile RAM on board the flow controller. The polynomial is applied to the instantaneous power measurement to convert the power signal to a flow signal. This flow signal is then converted to the desired engineering units and to the % of the desired full-scale flow. These flow signals are made available on the digital port. The % of full-scale signal is converted to the desired analog signal (0-5 Vdc, 0-10 Vdc or 4-20 mA). This signal is presented to the D connector in the same position as the analog 300 series.

In analog control mode the analog signal present on the command input pin is converted to a % of full-scale value. This % of full-scale command value is compared to the % of full-scale flow signal and an error signal is generated. The error signal is used to adjust the voltage supplied to the valve coil to adjust the actual gas flow to force the gas flow to match the desired flow. This measurement/control loop is performed approximately 1000 times a second to maintain real time control of the flow stream.

The following section contains the steps needed to get a new flow meter/controller operating as quickly and easily as possible. Please read the following thoroughly before attempting to install the instrument.

3. Installation & Operation

This section contains the necessary steps to assist in getting a new flow meter/controller into operation as quickly and easily as possible. Please read the following thoroughly before attempting to install the instrument.

3.1. Receiving Inspection

Prior to opening, inspect for obvious signs of damage to the shipment. Immediately advise the carrier who delivered the shipment if any damage is suspected. If the shipment has arrived intact, carefully unpack the meter/controller and any accessories that have been ordered. Inspect for any obvious signs of damage to the shipment. Immediately advise the carrier who delivered the shipment if any damage is suspected. Check each component shipped with the packing list. Insure that all parts are present (i.e., flow meter, power supply, cables, etc.). Optional equipment or accessories will be listed separately on the packing list. There may also be one or more OPT options on the packing list. These normally refer to special ranges or special gas calibrations. They may also refer to special helium leak tests or high pressure tests. In most cases, these are not separate parts, but special options or modifications built into the flow meter.

3.2. Power Requirements

The HFM-D-300 meter requires 15-30 Vdc, 5.5 watts (360 mA @ 15 volts) for proper operation. The HFC-D-302 controller requires 15-30 Vdc, 7.5 watts (500mA @ 15 volts). This voltage can be bipolar or unipolar, i.e., +/-12, +/-15 or 24 Vdc, as long as, together, they are regulated to within 50 mV ripple. Surge suppressors are recommended to prevent power spikes reaching the instrument. The Hastings power supplies described in Section 1.4.3 satisfies these power requirements.

3.3. Output Signal

The standard output of the flow meter is a 0-5 Vdc signal proportional to the flow rate. In the Hastings power supplies the output is routed to the display, and is also available at terminals on the rear panel. If a Hastings supply is not used, the output is available on pin 6 (H pin-out) of the "D" connector. It is recommended that the load resistance be no less than 2k Ω . If the optional 4-20 mA output is used, the load impedance must be selected in accordance with Section 4.

3.4. Quick Start

Quick Start

1. *Insure flow circuit mechanical connections are leak free*
2. *Insure electrical connections are correct (see label).*
3. *Shut off all flow & set command to 0 (no flow).*
4. *Allow 30 min. to 1 hour for warm-up.*
5. *Note the flow signal decays toward zero.*
6. *Insure zero flow; wait 2 minutes, then zero the instrument.*
7. *Instrument is ready for operation*

4. Setup

4.1. Mechanical Connections

The flow meter/controller may be mounted in any position as long as the direction of gas flow through the instrument follows the arrow marked on the bottom of the Instrument case label. The preferred orientation is with the inlet and outlet fittings on a horizontal plane. If operating with a dense gas or at high pressures, the instrument must be installed horizontally. When mounted in a different orientation, the instrument should be re-zeroed at zero flow with the system pressurized to the expected operating pressure. The smallest of the internal passageways in the 300 series is the diameter of the sensor tube and the annular clearance of the shunt. This varies with the range of flow and can be as small as 0.014" (0.36 mm) for the sensor tube and 0.006" (0.15 mm) for the shunt. It should be clear from this that the instrument requires adequate filtering of the gas supply to prevent blockage or clogging of the tube.

There are two mounting holes (#8-32) in the bottom of the transducer for securing to a mounting bracket. The standard inlet and outlet fittings for the 300 series are VCR-4, VCO-4 or 1/4" Swagelok. It is suggested that all connections be checked for leaks after installation. This can be done by pressurizing the instrument (do not exceed 500 psig unless the instrument is specifically rated for higher pressures) and applying a diluted soap solution to the flow connections.

4.2. Electrical Connections

4.2.1. Power Input

Apply a source of dc power to the input power pins. Since the Digital Metaline has its own internal switching power supply, the value of this voltage is flexible and anything between 15 to 30 volts will work. Determine the pin-out configuration for the instrument from the back label and see the pin-out below for connection. Note that typical bipolar flow controller supplies produce ± 15 Vdc. The voltage between the positive pins and the negative pins is 30 volts and is perfectly adequate. The Digital 300 series of instruments will not need connection to the power supply common for a bipolar supply.

POWER PIN-OUT

	H Pin-out	U Pin-out
+Vdc	11	4
-Vdc	9	11
Case Gnd	7	8

4.2.2. Analog Connection

If no analog control or output signals are needed or desired, skip the Analog Connection section and proceed to the Digital Connection section.

There are two versions of the assembled I/O card. One version supports voltage I/O and the other supports current I/O. The version is selected at time of purchase. See your shipping memo to determine which one was include with this instrument.

The voltage output version may be set to 5 volts full scale or to 10 volts full scale. The standard value is 5 Volts and will have been set as such unless another value was specified at time of order. The analog, full scale settings can be changed in the field with digital commands. The standard current I/O version is 4-20 mA full-scale. Selecting a full-scale value affects both the flow signal output and the command signal input.

Each of these inputs and outputs require two pins since they are isolated from each other and from the power supply. It is permissible to tie the minus pins together to generate a common signal to minimize the number of wires required for the voltage I/O versions. If this instrument is a flow meter only unit there is not any Analog Input signal and it is not necessary to connect these lines. Determine the pin-out configuration for the instrument from the back label and see the pin-out below for connection.

ANALOG SIGNAL PIN-OUT

	H Pin-out	U Pin-out
+ Analog Out	6	6
- Analog Out	5	13
+ Analog In	14	15
- Analog In	12	14

The current output versions can be operated using an isolated supply or by using the flow meter supply, (see figure 4.1).

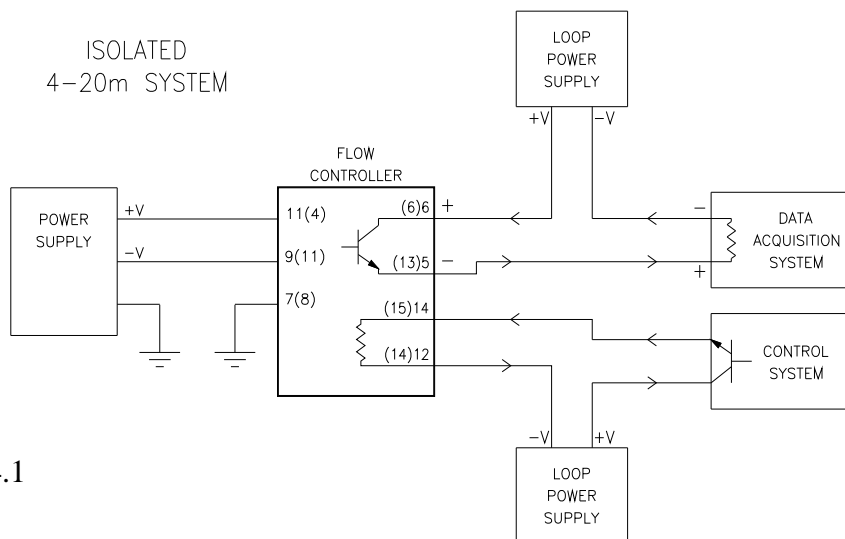
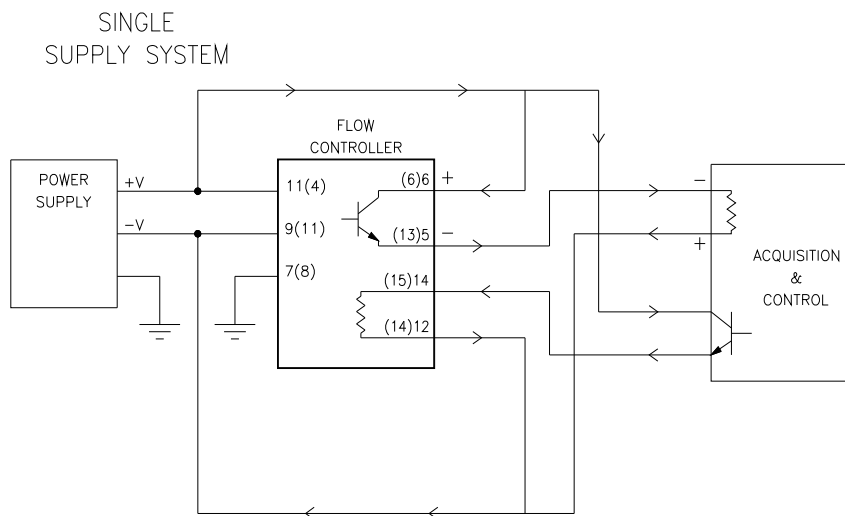

Fig. 4.1



Besides the standard control lines there is also another analog to digital converter on board that may be used to supply an external variable to be controlled by the PID loop instead of the flow signal. These inputs may also be used to provide signals that override the normal valve control. The default configuration is to allow these pins to provide valve override control, but this may be changed in the field with digital commands. If neither of these options is desired these lines may be ignored.

EXTERNAL OPTION PIN-OUT

	H Pin-out	U Pin-out
+ Option In	8	9
- Option In	15	1

4.2.3. Digital Connection

If this instrument is to emulate an analog instrument only, this section may be skipped.

The Digital 300 series has two, 6-pin, RJ12 ports on the top of the instrument for digital communication. These ports are in parallel. They may be used interchangeably. Two are provided to allow the daisy chaining of RJ12 cables between multiple instruments when using an RS485 bus. The Digital 300 series can be configured to operate with RS232 or RS485 signals. The instrument will be configured to one or the other, per request, at the time of the order (default = RS232). This may be changed in the field by the proper selection of internal jumpers.

Due to the lack of standards for serial communication using cables of this configuration, there is a jumper field, internal to the instrument, which allows great flexibility when setting up the communications to match an existing field configuration. See the Jumper Field section for this information. Hastings has chosen a cable configuration for our instruments and the instrument will be shipped with this configuration.

Hastings uses a full duplex configuration with center two pins tied to ground and the outer pins being the communication lines to provide protection if the cable is inadvertently reversed. See the table below for the standard pin-out:

COMMUNICATIONS CABLE PIN-OUT		
Pin#	RS232	RS485
1	<i>RTS</i>	<i>TX+ (TDB)</i>
2	<i>TX</i>	<i>TX - (TDA)</i>
3	<i>Ground</i>	<i>Ground</i>
4	<i>Ground</i>	<i>Ground</i>
5	<i>RX</i>	<i>RX - (RDA)</i>
6	<i>CTS</i>	<i>RX+ (RDB)</i>

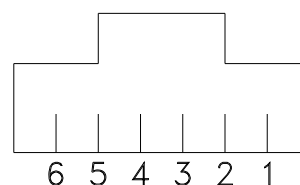

FEMALE
JACK

FIG 4.2

The pins are numbered looking into the female connector with the pins on the bottom from right to left. Note that the first two pins are signals coming from the Digital 300 to the buss master while the last two pins are signal coming to the Digital 300 from the buss master.

If making up a cable to interface to the standard PC 9-pin serial port use the following connections:

RJ12	D9 Female
NC	1
2	2
5	3
NC	4
4	5
NC	6
6	7
1	8
NC	9

The Digital 300 series uses RS485 receivers that are protected from buss over-voltages and will not be damaged if connected to a buss without a driver or pull up resistors. The I/O board also contains jumpers in the field to select 120-ohm termination resistors if this particular instrument is the last one in a long cable length (prevents miscommunications due to reflections). These are not normally necessary for short cables. Do not have more than one instrument with these resistors enabled on any one cable run as this will load down the cable. Hastings ships RS485 instruments without the resistors enabled, see the Jumper Field section if these resistors are necessary.

The default port set-up is 19.2K baud, 8 data bits, no parity and no flow control. A “carriage return” signals the end of command input. The end of a response message from the Digital 300 is signaled by a “>” character.

These values can be changed with digital commands.

4.2.4. Analog Operation

The Digital 300 series will go through an internal self check upon power up. This is indicated by one green and one red flashing LED on the top panel. After about 30 seconds the instrument will complete its initiation and drop into operation. The second led remaining a steady green will signify this. At this point the flow controller is monitoring the analog command signal and is controlling the flow to match the desired flow. The network LED will blink whenever the Digital 300 receives a valid command on the digital port.

There are two rotary encoders on the top of the Digital 300. The encoders replace the duties of standard analog zero and span potentiometers. These encoders may be enabled or disabled by using the MFM Configuration Word (S 2). See MFM Configuration Word section for further information. Typically the factory default will have the span encoder disabled and the zero encoder enabled. Turning them clockwise will increase the flow reading and counter-clockwise will decrease the reading. The speed with which they are turned affects their sensitivity. Turning an encoder quickly will make a bigger change for a given amount of rotation then for a slow turn. Do not make any adjustments using these unless the instrument has been operating for the full warm up period.

The encoder closest to the center is the zero potentiometer. If the auto-zero is active this adjustment will not normally be necessary for controllers. The one closest to the outside is the span potentiometer. Do not adjust the span encoder unless a calibration reference is available to adjust the flow properly as this encoder affects the calibration.

4.2.5. Jumper Field

To change from RS232 to RS485 or vice versa, move the jumper on H1 to the appropriate position as shown in figure 4.3 & 4.4, also push dipswitch 1 ON to enable RS485 & dipswitch 2 ON to enable addressing mode.

To activate the termination resistors on the last instrument of the 485 bus, install 2 jumpers across the bottom pins of H3 as shown in Fig 4.5.

If the polarity of the transmitter or receiver signal needs to be reversed on an RS485 bus, the jumpers on H3 can be rotated to accomplish this, See fig 4.6.

The H2 jumper set is used to tie unused pins to ground. Normally the center two pins are tied to ground. If necessary this can be changed by moving or removing jumpers.

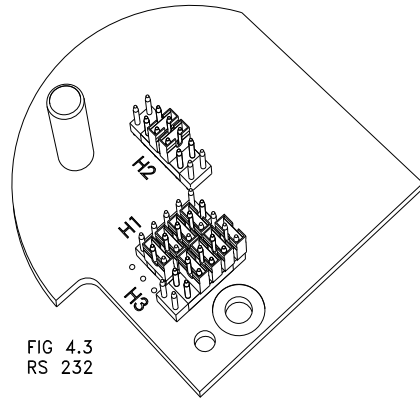

FIG 4.3
RS 232

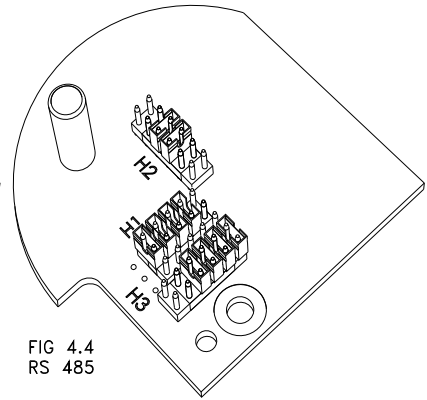

FIG 4.4
RS 485

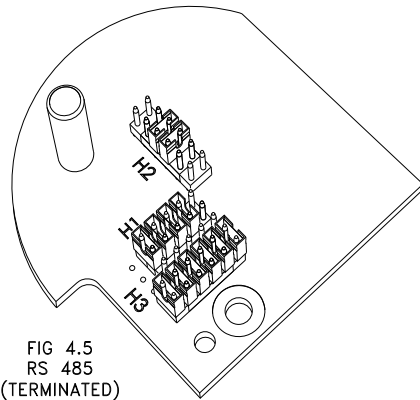

FIG 4.5
RS 485
(TERMINATED)

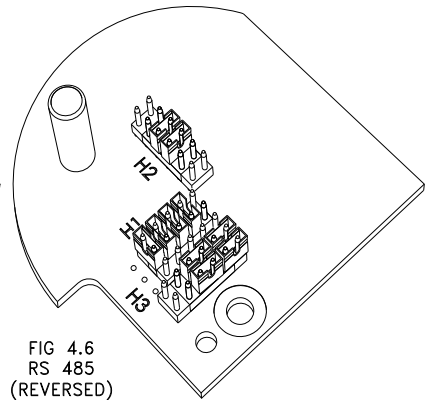
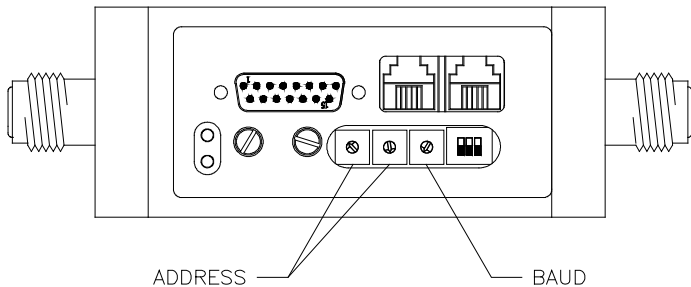

FIG 4.6
RS 485
(REVERSED)

5. Digital Communication

5.1. Basics

There are three BCD encoders on top of the Digital 300 series. The encoder on the inlet side is the port speed selector. When the pointer is set to 4, the speed is 19.2K baud (default). Adjusting it counter clockwise decreases the buss speed according to the following table.



BAUD RATE SETTINGS	
#	Baud
4	19.2k
3	9600
2	4800
1	2400
0	1200

The other two BCD encoders select the address for the instrument for RS485 communication. The encoder most downstream sets the most significant digit (MSD). The encoder in the center chooses the least significant digit (LSD). For example if the downstream encoder points to 3 and the center encoder points to 1 the address is 31. Any address up to 63 may be selected.

The other, default port settings are
8 data bits,
no parity,
no flow control.

A “carriage return” signals the end of command input. The end of a response message from the Digital 300 is signaled by an ASCII “>” character.

Note: in the following explanation [LF] and [CR] are used. Do not send these literal values send a “line feed” and “carriage return” respectively.

In the following examples, command ECHO is enabled in the application on the computer used to communicate with the Digital 300 unit. ECHO is not required but will make a difference in what is seen as a response on some terminals.

Connect the Digital 300 to a computer port set to the conditions outlined above. Send the following:

```
F[CR][LF]
```

The terminal should respond with:

```
F[CR][LF]
```

```
0.0123[CR][LF]>
```

The number 0.0123 will be different depending on the flow rate present at the time of communication. “F” is the command requesting the present flow rate. It may be upper or lower case.

ZRO[CR][LF] will reset the Zero

If the instrument is operated in RS485 mode, all of the commands mentioned in this manual must be preceded by the attention character “*” and the address.

Ex) To request the flow from an instrument at address 01, use the following:

```
*01[SPACE]F[CR][LF]
```

The spaces after the attention character & the address are required. The address must be 2 characters.

5.2. Operating States

The Digital 300 series is designed to operate as a state machine. It has different operating states that have different operating characteristics. Most of these states were modeled after the state requirements of the ODVA organization for the Devicenet® specification.

INIT

When the Digital 300 is initially energized it starts in the INIT state (state 1) in order to perform self tests and to start the sensor bridge control loop. One of the LEDs on the top of the cover will flash red while the processor remains in this state. The processor will respond to queries in this state but will not control gas flow.

All flow reading responses will have an "I" appended to the end to signal that the flow may not be valid since the flow controller has not yet completed its self-tests. The processor will hold the valve in the default position while in the INIT state. After successfully initiating sensor operation and retrieving valid sensor power readings, the processor will automatically transition into the IDLE state (state 2). If the processor hangs in the INIT state more than approximately 30 seconds then it is probably an indication of sensor failure.

IDLE

In the default configuration, the Digital 300 series will transition immediately out of IDLE state and directly into the OPERATE state. This can be changed by clearing a bit in the MFM Configuration word to allow the Digital 300 to remain in the IDLE state as specified by ODVA for the Devicenet® specification (see the Network Control section and the Software Manual for more information). Some of the other states such as OPERATE, CAL or TEST can only be reached with a transition from IDLE state. The flow readings are accurate in this state but automatic valve control is not enabled. Manual valve control can be used to control the flow while in this state. Some of the configuration settings may only be changed in this mode to prevent uncontrolled valve conditions.

OPERATE

Normal control is accomplished by a transition to the OPERATE state either automatically or by reception of a change state command. In the OPERATE state the Digital 300 series can report flow readings and respond to changes in the flow command (digital or analog). As shipped by Hastings the Digital 300 will monitor the analog command line for the desired flow command (set-point). The choice of the flow command source can be changed from the analog input to the digital port (network) by clearing a bit in the MFC Configuration word (see the Network Control section and the Software Manual for more information).

CAL

CAL State is used when setting up the power levels for the 10 Calibration instances. The Digital 300 series is capable of storing correction data for 10 different calibrations including the gas sensitivities of the sensor and the linearization coefficients to correct for the small errors in the flow splitting which are dependent on the gas density. The instrument is shipped from Hastings with Cal instance "0" set up for nitrogen. Cal instance "1" will be setup for the primary gas requested at the time of order. Other Cal instances may be setup for other conditions or gasses as requested. The Cal instance may be queried to determine the gas. There is also a comment section that may be queried for additional information. See the Software Manual for more information.

5.3. Digital Control

In order to change from analog control to digital control, issue the following commands:

V[space][2][space]=[x41][CR][LF]	This disables analog flow commands and enables digital flow commands.
----------------------------------	---

If the meter/controller has been operating in the analog mode, the default STATE will have been OPERATE and the next command should be unnecessary. If the unit has been operating in any other state and it is desired to have the flow controller automatically restart upon power up, issue the following command:

S[space][2][space]=[xFC55][CR][LF]

This enables the automatic transition to the OPERATE state.

Future flow commands may be sent with this command:

V[space][4][space]=[value][CR][LF]

This sends a flow command in engineering in engineering units.

If flow commands as a % of full scale are preferred the following command may be used.

V[space][5][space]=[value][CR][LF]

5.3.1. Menus/Lists

There are a number of commands that will dump a large amount of information about the status of the flow controller. Following are the List commands.

5.3.2. Sensor

The first list is the sensor list, which is activated with the following command:

SL[CR][LF]

The Digital 300 series instrument will reply with something similar to:

```
item 1 : MODEL-??? V d.dda
item 2 :sys config: x2FC55
item 3 :port rate: 19.2K BPS
item 4 :port rate: 19200 BPS
item 5 :macid : 44
item 6 :active gas inst: 0
item 7 :flow alarm enable: 1
item 8 :flow alarm delay: 3. S
item 9 :flow warn enable: 1
item 10:flow warn delay: 2. S
item 11:FS volts: 10. V
item 12:flowing hours: 2.7913e+2 H
item 13:cal state inst: 0
```

A large number of other items may also be returned. Each line is terminated with a carriage return and line feed. Each of these lines contains item number, a description and a value. If a number is preceded with an “x,” the following value is in hexadecimal format. See the *Hexadecimal* section of the *Software Manual* for more information on this format.

Individual items may be accessed by:

S[space][item#][CR][LF]

There must be a space between the “S” character and the item#.

User changeable items may be changed by sending:

S[space][item#][space]=[value][CR][LF]

There must be a space between the item# character and the “=”, but there cannot be a space between the “=” and the value. Hexadecimal values must be preceded by an “x”.

Item 2 is the MFM Configuration word that can be used to setup various configuration parameters of the instrument such as the IDLE state behavior, alarm enables and various selections for the amount of text that the Digital 300 uses to respond to queries. See the *Software Manual* for more information.

Item 3 is the port rate for the factory port which is not accessible from the outside of the instrument. Do not adjust.

Item 4 is the port speed as set by the encoder on the top of the instrument.

Item 5 is the instrument multi-drop address as set by two encoders on the top of the instrument.

Item 6 shows the particular gas instance which is being used to generate flow readings. Changing this value will switch between the 10 different gas calibrations that may be present in the Digital 300 series.

Item 11 shows the analog signal value that signifies Full Scale. This may be changed to change the analog output at the full scale flow rate. Recalibration may be required.

Item 12 shows the number of hours that this particular instrument has been actually flowing gas

Some of the other values are read only or for troubleshooting use. There are values which may be set to change the end of message character (prompt) from the ">" character or to change the character that the Digital 300 uses to signal a new line.

5.3.3. Gas

The next list is the gas list, which is activated with the following command:

```
GL[CR][LF
```

The Digital Metaline will reply with:

```
item 1 :gas instance: 0
item 2 :instance mode: READY
item 3 :gas code: 8
item 4 :gas symbol: Air
item 5 :units code: 0
item 6 :units name: std.cubic cm/minute
item 7 :units symb: SCCM
item 8 :units ratio: 1000.
item 9 :hi alarm limit: 374.99 SCCM
item 10:hi alarm limit: 75.%
item 11:low alarm limit: 125. SCCM
item 12:low alarm limit: 25.%
item 13:hi warn limit: 1.4953 SCCM
item 14:hi warn limit: .29907%
item 15:low warn limit: 187.49 SCCM
item 16:low warn limit: 37.5%
item 17:span corr factor: 1.
item 18:FS flow: 499.99 SCCM
item 19:cal inst: 0
item 20:cal inst gas code: 13
item 21:cal inst gas: N2
item 22:cal inst FS flow: 500. SCCM
item 23:linz instance: 1
item 24:linz coef 1: 1.
item 25:linz coef 2: .01431
item 26:linz coef 3: .02338
item 27:linz coef 4: -.2857
item 28:linz coef 5: .3456
item 29:FS flow pwr diff: .027076 W
item 30:integrated flow: 4.6382 WH
item 31:integrated flow: 5.1389e+06 SCC
```

Other items may be returned with the gas list. The individual items are accessed and altered the same way as shown under the sensor list except the first character is a "G".

Item 4 shows the gas for which this particular calibration is valid.

Item 5 shows the units code. This selects the engineering units used. The LUNT command will list out the units available and their associated units code. Changing these units will not invalidate the calibration. The Digital 300 will change all of its reports to the new unit.

Item 6 shows the engineering units that the flow reading (F command) uses when reporting the flow rate.

Items 9 – 16 are the values in flow rates and % of full scale which will trigger alarms and warnings if they are enabled.

Item 18 shows the full scale flow rate for this gas record.

Items 19 – 29 show information from the calibration instance used by this gas instance.

Item 31 shows the total flow that has passed through this instrument in the currently selected engineering units. Total flow in a chamber can be monitored by setting this to zero before fill at G31=0.

5.3.4. Valve

The valve list is activated with the following command:

```
VL[CR][LF
```

The Digital Metaline will reply with:

```
item 1 :MFC mode: 1
item 2 :MFC config: x41
item 3 :valve mode: x20
item 4 :netwk setpt: 99.975 SCCM
item 5 :netwk setpt: 19.995%
item 6 :cmmd setpt: 99.975 SCCM
item 7 :cmmd setpt: 19.995%
item 8 :impl setpt: 99.975 SCCM
item 9 :impl setpt: 19.995%
item 10:cntrlld var: 105.95%
item 11:cntrlld var: 529.81 SCCM
item 12:softstart type: x00
item 13:softstart value: 1000
item 14:trckg error: *
item 15:trckg error: *
item 16:trckg alarm limit: 12.481 SCCM
item 17:trckg alarm limit: 2.4963%
item 18:trckg alm enable: 1
item 19:trckg alarm delay: 4. S
item 20:trckg warn limit: 27.496 SCCM
item 21:trckg warn limit: 5.4992%
item 22:trckg warn enable: 1
item 23:trckg warn delay: 5. S
item 24:PID gain coeff: 200
item 25:PID rate coeff: 200
item 26:PID intg coeff: 500
item 27:valve drive: 38000
item 28:valve set: 19000
```

Other items may be listed besides those mentioned above. The individual items are accessed and altered the same way as shown under the sensor list, except the first character is a “V”.

Item 1 determines the valve control type. This value must be set to 1 for normal closed loop flow control.

value = 0: DEFAULT mode. Valve is set into the user default position as specified in MFCMODE_VALVEDEF . Automatic closed-loop action is disabled.

value =1: AUTO mode. Automatic closed-loop operation is enabled. Valve position is controlled to maintain flow at the implemented set-point.

value =2: HOLD mode. Automatic closed-loop operation is suspended. Valve drive is maintained constant. Can be set only from AUTO mode while in OPERATE state. If instrument is reset or repowered while in HOLD mode, valve position will revert to the user defined default position.

value =3: SHUT . Valve is set to the shut position. Automatic closed-loop operation is disabled.

value = 4: PURGE - Valve is set to the full-open position. Automatic closed-loop operation is disabled.

value = 5: VARIABLE (or “manual”) Valve drive is controlled by network command (“V 28”), or by analog voltage input as chosen in the MFC (Flow Controller) Configuration Word (Data item “V 2”). Automatic closed-loop operation is disabled.

value = 6: ERROR. Valve is set into the user default position as specified in MFCMODE_VALVEDEF . Automatic closed-loop action is disabled. If instrument is reset or repowered while in ERROR mode, MFC mode will become DEFAULT and valve position will revert to the user defined default position. The ERROR mode may be set by internal detection of an error condition, or by network command. Once set, the ERROR mode is maintained until changed by user. These operations are not intended as safety features.

Item #2 is the MFC Configuration word. This word controls the source of the flow command (set-point), the source of the controlled variable and the source of the valve override, and the default valve position. Bits 6 & 7 control the set-point source if bit 7 is clear and bit 6 is set as shown in the previous valve list the set-point is controlled from the network. If bit 7 is set and bit 6 is clear i.e. if the previous MFC Configuration word were changed from x41 to x81 {V[space][2][space]=[x81][CR][LF]} the set-point source would change from the network to the signal on the flow command pin. See the Software Manual for more information.

Item 4 is command set-point acquired from the digital network. If item 2 (MFC Configuration word) is set for network control, item 4 or item 5 may be used to set the desired flow rate.

V[space][4][space]=[value][CR][LF]

Item 13 controls the ramp rate, decreasing this value will minimize over shoots.

Items 14 to 23 control the tracking error and warnings. Tracking here refers to how closely the measured flow rate “tracks” the flow command (set-point).

Items 24 – 26 are the close loop PID (Proportional-Integral-Derivative) coefficients which may be changed to improve the loop response and stability. Decreasing Item 26 will slow down the value response to changes in command.

Item 28 is the valve drive set for manual control of the valve. A value of 0 will remove all current from the valve. A value of 40000 will supply the maximum current possible to the valve.

6. Operation

The standard instrument output is a 0 - 5 VDC signal and is proportional to the flow. i.e., 0 volts = zero flow and 5 volts = 100% of rated flow. The 4 - 20 mA option is also proportional to flow, 4 mA = zero flow and 20 mA = 100% of rated flow.

6.1. Operating Conditions

For proper operation, the combination of ambient temperature and gas temperature must be such that the flow meter temperature remains between 0 and 60°C. The most accurate measurement of flow will be obtained if the flow meter is zeroed at operating temperature as temperature shifts result in some zero offset. The 300 series is intended for use in non-condensing environments only. Condensate or any other liquids which enter the flow meter may destroy its electronic components.

6.2. Zero Check

Turn the power supply on if not already energized. Allow for a 1 hour warm-up. Stop all flow through the instrument and wait 2 minutes. **Caution:** Do not assume that all metering valves completely shut off the flow. Even a slight leakage will cause an indication on the meter and an apparent zero-shift. Reset the zero using the "ZRO" command, by allowing the auto-zero to activate or by adjusting the zero potentiometer located on the top of the flow meter until the meter indicates zero flow. This zero should be checked periodically during normal operation. Zero adjustment is required if there is a change in ambient temperature, or vertical orientation of the flow meter / controller.

6.3. High Pressure Operation

When operating at high pressure, the increased density of gas will cause natural convection to flow through the sensor tube if the instrument is not mounted in a level position. This natural convection flow will be proportional to the system pressure. This will be seen as a shift in the zero flow output that is directly proportional to the system pressure.

If the system pressure is higher than 250 psig(1.7 MPa) the pressure induced error in the span reading becomes significant. The following chart shows the mean error and the minimum/maximum expected span errors induced by high pressures for the low flow sensors. This error will approach 16% at 1000 psig.

Instruments with different flow ranges require sensors with different sensor tube inner diameters (ID's). The charts below show the pressure effect for sensors with different sensor tube ID's.

For accurate high pressure measurements this error must be corrected.

The formulae for mean error, expressed as a fraction of the reading, are:

$$Error_{26} = (9.887 * 10^{-11})P^3 - (3.4154 * 10^{-7})P^2 + (8.3288 * 10^{-5})P, \quad (0.026" \text{ Sensor})$$

$$Error_{17} = (1.533 * 10^{-10})P^3 - (3.304 * 10^{-7})P^2 + (1.8313 * 10^{-4})P, \quad (0.017" \text{ Sensor})$$

$$Error_{14} = (-1.692 * 10^{-10})P^3 + (1.776 * 10^{-7})P^2 - (1.929 * 10^{-5})P, \quad (0.014" \text{ Sensor})$$

Where P is the pressure in psig and *Error* is the fraction of the reading in error.

The flow reading can be corrected as follows:

$$Corrected = Indication - Full \text{ Scale} * Error$$

Where the *Indication* is the indicated flow, *Full Scale* is the full scale reading and *Error* is the result of the previous formula (or read from charts below).

Fig 6.1

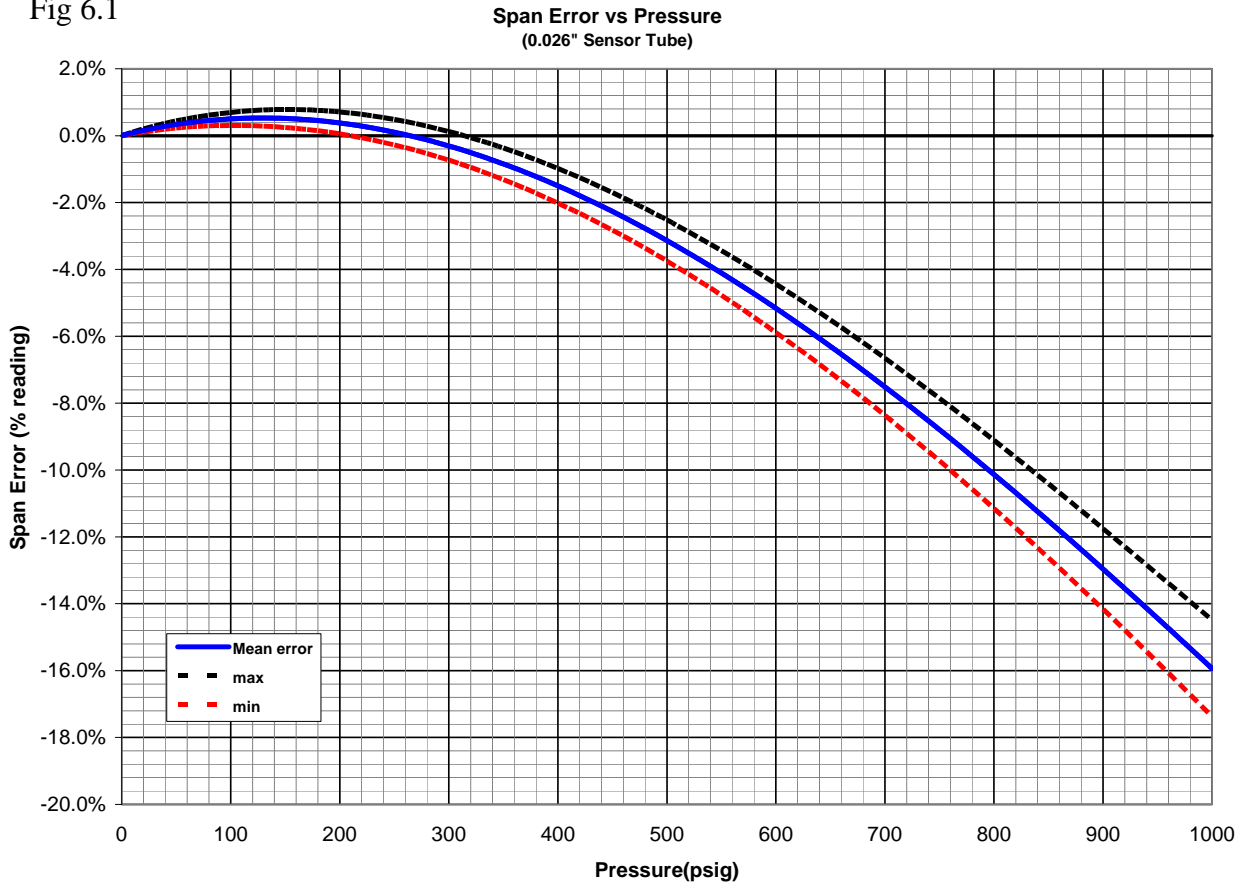
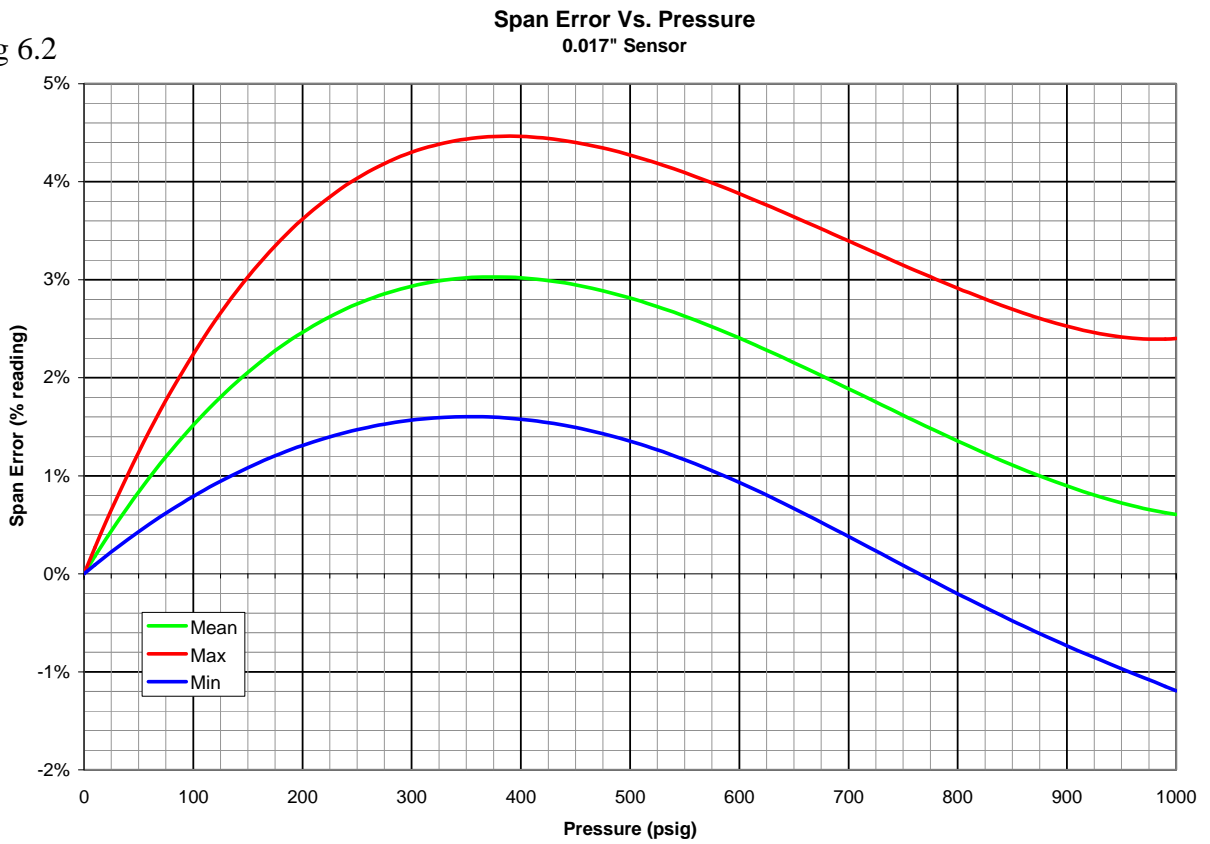

Fig 6.2



Pressure Span Error for 0.014" Sensor

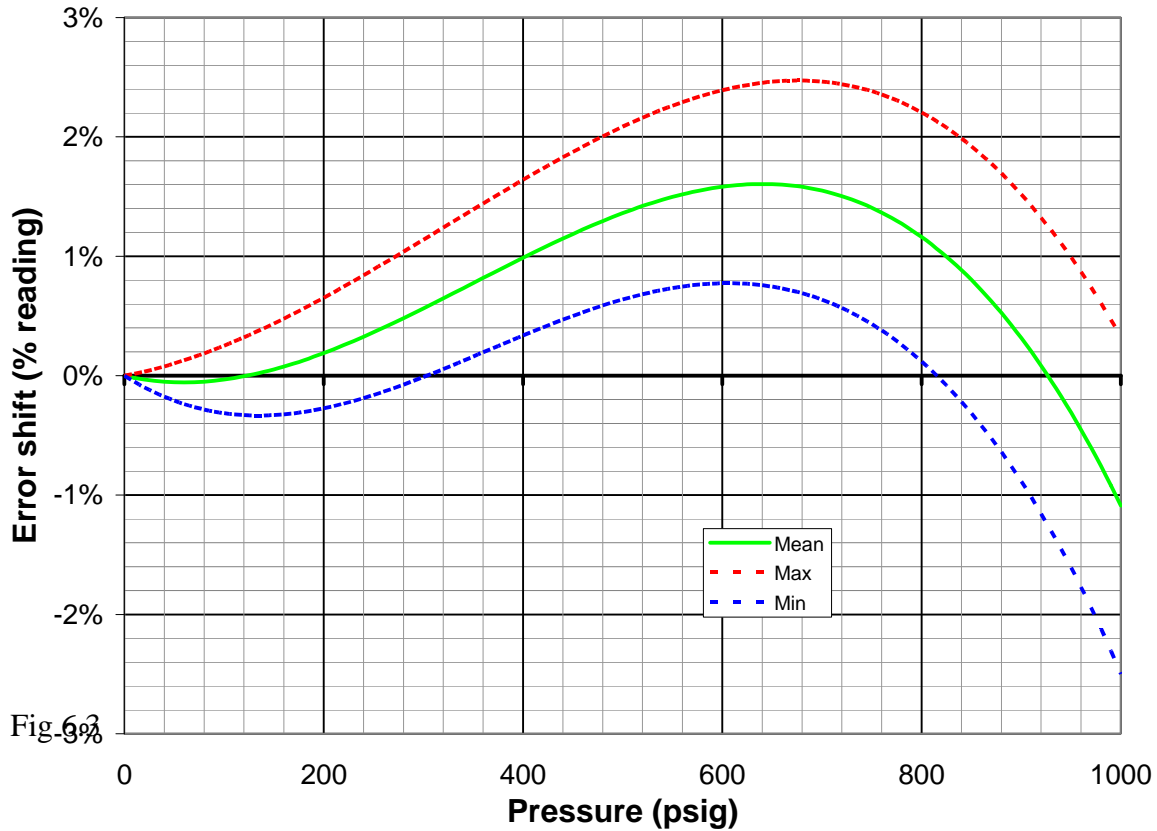

Fig. 6-3

6.4. Blending of Gases

In the blending of two gases, it is possible to maintain a fixed ratio of one gas to another. In this case, the output of one flow controller is used as the reference voltage for the set-point of a second flow controller. The set-point then provides a control signal that is proportional to the output signal of the first flow controller, and hence controls the flow rate of the second gas as a percentage of the flow rate of the first gas.

EXAMPLE: Flow controller A has a 0-100 SLM range with a 5.00 volt output at full scale. Flow controller B has a 0-10 SLM range with a 5.00 volt output at full scale. If flow controller A is set at 80 SLM, its output voltage would be 4.00 volts (80 SLM/100 SLM x 5.00 volts = 4.00 volts). If the output signal from flow controller A is connected to the command input of flow controller B, it then becomes a variable reference voltage for flow controller B proportional to the flow rate of flow controller A.

If the set-point input of flow controller B is set at 50% of full scale, and the reference voltage from flow controller A is 4.00, then the command signal going to flow controller B would be 2.00 volts (4.00 volts x 50.0% = 2.00 volts). The flow of gas through flow controller B is then controlled at 4 SLM (2.00 volts/5.00 volts x 10 SLM = 4 SLM).

The ratio of the two gases is 20:1 (80 SLM/4 SLM). The % mixture of gas A is 95.2 (80 SLM/84 SLM) and the % mixture of gas B is 4.8% (4 SLM/84 SLM).

Should the flow of flow controller A drop to 78 SLM, flow controller B would drop to 3.9 SLM, hence maintaining the same ratio of the mixture. (78 SLM/100 SLM x 5v = 3.90v x 50% = 1.95v; 1.95v/5.00v x 10 slpm = 3.9 slpm; 78 slpm:3.9 slpm = 20:1)

6.5. Controlling Other Process Variables

Normally, a flow controller is setup to control the mass flow. The control loop will open and close the valve as necessary to make the output from the flow measurement match the input on the command line. Occasionally, gas is being added or removed from a system to control some other process variable. This could be the system

pressure, oxygen concentration, vacuum level or any other parameter which is important to the process. If this process variable has a sensor that can supply an analog output signal proportional to its value then the flow controller may be able to control this variable directly. This analog output signal could be 0-5 volts, 0-10 volts (or 4-20 ma for units with 4-20 ma boards) or any value in between.

This process variable signal must be supplied on the Option In pins (8 & 15 for H, 9 & 1 for U) of the D connector. When the controller is set for external variable control it will open or close the valve as necessary to make the external process variable signal match the command signal. The command signal may be 0-5 volts, 0-10 volts (4-20 ma for 4-20 ma input/output cards) or any value in between. If the process variable has a response time that is much faster or slower than the flow meter signal it may be necessary to adjust the PID values.

6.6. Command Input

The flow controller will operate normally with any command input signal between 0-10 volts (4-20ma for units with 4-20 ma input/output cards). During normal operation the control loop will open or close the valve to bring the output of the flow meter signal to within ± 0.001 volts of the command signal. The command signal will not match the flow signal if there is insufficient gas pressure to generate the desired flow.

If the command signal is less than 1% of full scale (0.05 volts or 4.16 ma) the valve override control circuit will activate in the closed position. This will force the valve completely closed regardless of the flow signal.

6.7. Valve Override Control

A/D #0 or A/D #1 may be used to control valve mode or as input for the controlled variable and A/D #1 may be for the flow control set-point input. The "MFC config:" word in the valve menu controls this (V 2). See the software manual for configuration information.

For valve override, valve shut and purge thresholds are implemented as ratios relative to full scale. The values are hard coded at 10% and 50% of full scale, respectively. Therefore, if an instrument is configured and calibrated for 10.00V full scale, the valve shut/purge thresholds are at 1.00 and 5.00 volts for voltage mode. If an instrument is configured and calibrated for 20.00mA full scale, the effective span will be 16.00mA, and therefore the valve-shut threshold will be $4.00 + 1.60 = 5.6\text{mA}$, and the valve purge threshold should be $4.00 + 8.00 = 12.00\text{mA}$.

However at this time the purge action for 4 - 20 mA and 1 - 5 Volt versions is not operational. Exceeding the purge threshold with these two versions will activate the valve shut operation.

(Note: a hysteresis band is applied to the 10% and 50% thresholds (-1% to +1% around 10% and 50%, respectively).

If an instrument has been set up to work with the valve override switch on the Hastings THPS-400 (or older Model 200/400) power supply there will be a couple of component changes to the pc board that will prevent A/D #0 from working as an external variable input and milliamp versions will have A/D #0 set up to operate from a voltage signal.

7. Theory of Operation

This section contains an overall functional description of the Digital 300 series of flow instruments. In this section and other sections throughout this manual, it is assumed that the customer is using a Hastings power supply.

7.1. Overall Functional Description

The 300 series consists of a sensor, base, shunt, control valve and electronic circuitry. The sensor is configured to measure gas flow rate from 0 to 5 sccm, 0 to 10 sccm, or 4 to 20 sccm, depending on the customer's desired overall flow rate. The shunt divides the overall gas flow such that the flow through the sensor is a precise percentage of the flow through the shunt. The flow through both the sensor and shunt is laminar. The control valve adjusts the flow so that the sensor's measurement matches the set-point input. The circuit board amplifies the sensor output from the two RTD's (Resistive Temperature Detectors) and provides an analog output of either 0-5 VDC or 4-20 mA.

7.2. Sensor Description

A cross section of the sensor is shown in Figure 7.1. The sensor consists of two coils of resistance wire with a high temperature coefficient of resistance (3500 ppm/°C) wound around a stainless steel tube with known diameter (d) and length (l). Each coil has the same length and they are separated by 1.27 mm distance. These two identical resistance wire coils are used to heat the gas stream and are symmetrically located upstream and downstream on the sensor tube. Insulation surrounds the sensor tube and heater coils with no voids around the tube to prevent any convection losses. The ends of this sensor tube pass through an aluminum block and into the stainless steel sensor base. This aluminum block thermally shorts the ends of the sensor tube and maintains them at ambient temperature.

There are two coils of resistance wire that are wound around the aluminum block. The coils are identical to each other, and are symmetrically spaced on the aluminum ambient block. These coils are wound from the same spool of wire that is used for the sensor heater coils so they have the same resistivity and the same temperature coefficient of resistance as the sensor heater coils. The number of turns is controlled to have a resistance that is 10 times larger than the resistance of the heater coils. Thermal grease fills any voids between the ambient temperature block and the sensor tube to ensure that the ends of the sensor tube are thermally tied to the temperature of this aluminum block.

Aluminum has a very high thermal conductivity which ensures that both ends of the sensor tube and the two coils wound around the ambient block will all be at the same temperature. This block is in good thermal contact with the stainless steel base to ensure that the ambient block is at the same temperature as the main instrument block and, therefore, the same temperature as the incoming gas stream. This allows the coils wound on the aluminum block to sense the ambient gas temperature.

Two identical Wheatstone bridges are employed, as shown in Figure 7.2. Each bridge utilizes an ambient temperature sensing coil and a heater coil. The heater coil and a constant value series resistor comprise the first leg of the bridges. The second leg of each bridge contains the ambient sensing coil and two constant value series resistors. These Wheatstone bridges keep each heater temperature at a fixed value of $\Delta T = 48^\circ\text{C}$ above the ambient sensor temperature through the application of closed loop control and the proper selection of the constant value bridge resistors.

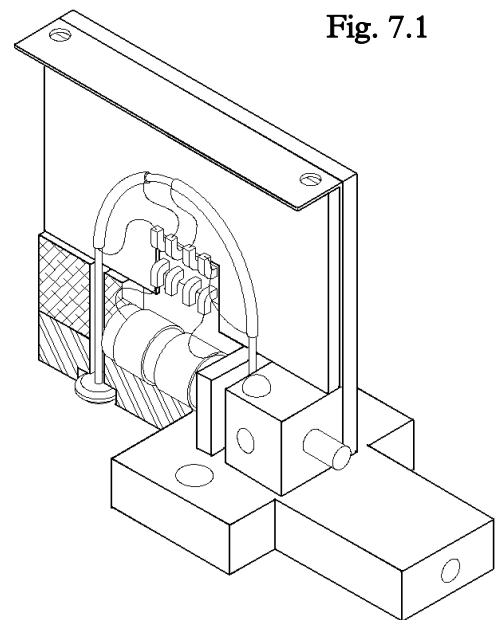

Fig. 7.1

7.3. Sensor Theory

Consider the sensor design shown in Figure 7.1. The degree of heat convection to or from a fluid is proportional to the mass flow of that fluid.

Since the constant differential temperature sensor has two heater coils symmetrically spaced on the sensor tube, it is convenient to consider the upstream and downstream heat transfer modes separately.

The electrical power supplied to either of the heater coils will be converted to heat, which can be dissipated by radiation, conduction, or convection. The radiation term is negligible due to the low temperatures used by the sensor and because the sensor construction preferentially favors the conductive and convective heat transfer modes. The thermal energy of each heater will then be dissipated by conduction down the stainless steel sensor tube, conduction to the insulating foam, plus the convection due to the mass flow of the sensed gas.

Because great care is taken to wind the resistive heater coils symmetrically about the midpoint of the tube, it is assumed that the heat conducted along the sensor tube from the upstream heater will be equal to the heat conducted through the tube from the downstream heater. Similarly, the heat conducted from the upstream and downstream coils to the foam insulation surrounding them is assumed to be equal, based on the symmetry of the sensor construction.

Since the sensor tube inlet and outlet are linked by an aluminum ambient bar, the high thermal conductivity of the bar provides a 'thermal short', constraining the ends of the sensor tube to be at equal surface temperature. Moreover, the tube ends and the aluminum ambient bar have intimate thermal contact with the main flow passageway prescribed by the main stainless steel flow meter body. This further constrains each end of the sensor tube to be equal to the ambient gas temperature.

Further, since the length of each heater section is nearly 21 times greater than the inside tube diameter, the mean gas temperature at the tubes axial midpoint is approximately equal to the tube surface temperature at that point. Recall that the outside of the sensor tube is well insulated from the surroundings; therefore the tube surface temperature at the axial midpoint is very close to the operating temperature of the heater coils. The mean temperature of the gas stream is then approximately the same as the heater temperature. Assuming the mean gas temperature is equal to the heater temperature, it can be shown that the differential pressure is:

$$P_{\mu} - P_d = 2 \dot{m} C_p (T_{heater} - T_{ambient}) \quad (7.1)$$

The value of the constant pressure specific heat of a gas (C_p) is virtually constant over small changes in temperature. By maintaining both heaters at the same, constant temperature difference above the ambient gas stream temperature, the difference in heater power is a function only of the mass flow rate. Fluctuations in ambient gas temperature, which cause errors in conventional mass flow sensors, are avoided. The resistance of the ambient sensing coil changes proportionally with the ambient temperature fluctuations, causing the closed loop control to vary the bridge voltage such that the heater resistance changes proportionally to the ambient temperature fluctuation.

The power supplied to each of the two heater coils is easily obtained by measuring the voltage across the heater, shown as V_2 on Figure 7.2, and the voltage across the fixed resistor R_1 . Since R_1 is in series with the heater (R_{ht}) they have the same current flowing through them. The electrical power supplied to a given heater is then calculated:

$$P = \frac{(V_1 - V_2)V_2}{R_1} \quad (7.2)$$

With a constant differential temperature applied to each heater coil and no mass flow through the sensor the difference in heater power will be zero. As the mass flow rate through the sensor tube is increased, heat is transferred from the upstream heater to the gas stream. This heat loss from the heater to the gas stream will force the upstream bridge control loop to apply more power to the upstream heater so that the 48°C constant differential temperature is maintained.

The gas stream will increase in temperature due to the heat it gains from the upstream heater. This elevated gas stream temperature causes the heat transfer at the downstream heater to gain heat from the gas stream. The heat gained from the gas stream forces the downstream bridge control loop to apply less power to the downstream heater coil in order to maintain a constant differential temperature of 48°C.

The power difference at the RTD's is a function of the mass flow rate and the specific heat of the gas. Since the heat capacity of many gases is relatively constant over wide ranges of temperature and pressure, the flow meter may be calibrated directly in mass units for those gases. Changes in gas composition require application of a multiplication factor to the nitrogen calibration to account for the difference in heat capacity.

The sensor measures up to 20 sccm full scale flow rate at less than 0.75% F.S. error. The pressure drop required for a flow of 20 sccm through the sensor is approximately 0.5 inches of H₂O (125 Pa).

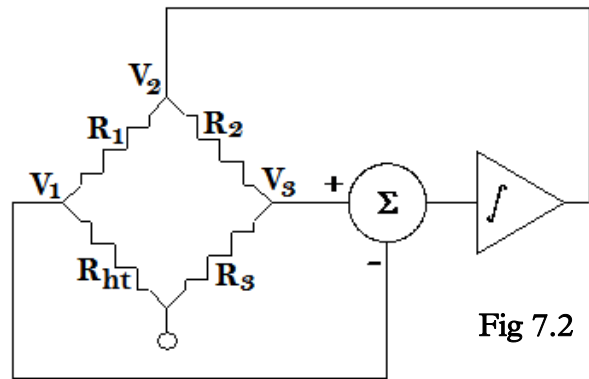
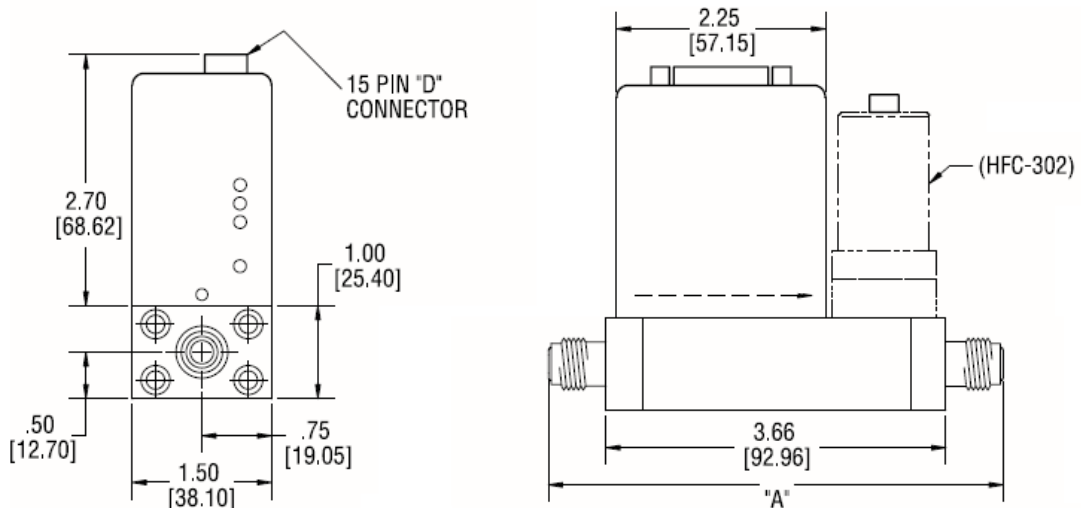

Fig 7.2

7.4. Base

The dimensions for the 316 stainless steel base can be found in the diagrams that follow. Metal to metal seals are used between the base and end-caps, as well as the base and sensor module. Gaskets made of nickel 200 are swaged between mating face seals machined into the stainless steel parts. All metal seals are tested at the factory and have leak rates of less than 1x10⁻⁹ std. cc/s. Because of this corrosion resistant, all metal sealed design, the 300 series can measure corrosive gases that would damage elastomer sealed flow meters.

Models HFM-300 & HFC-302



FITTING TYPE	DIM "A"
9/16"-18 FEMALE	4.05 [102.87]
SWAG 1/8" W NUT	5.09 [129.29]
SWAG 1/8" BARE	4.57 [116.08]
SWAG 1/4" W NUT	5.15 [130.81]
SWAG 1/4" BARE	4.57 [116.08]
VCO FACE 1/4"	4.57 [116.08]
VCR FACE 1/4"	4.88 [123.95]

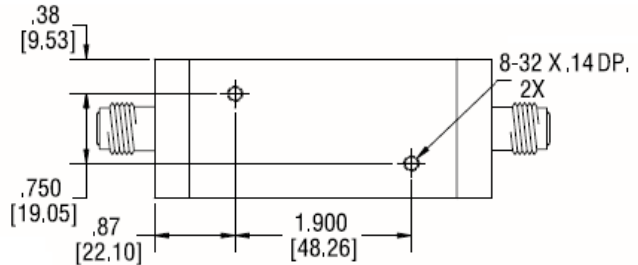

7.5. Shunt description

The flow rate of interest determines the size of the shunt required. A different shunt is required for each flow meter/controller of a particular range. Hastings Instruments carries several different shunts spanning the full flow range of the 300 series. These shunts employ a patented method of flow division, which results in a more linear flow meter. As a result, the 300 series flow meter calibration is more stable when changing between measured gases.

The shunt used for flow rates up to and including a 200 sccm equivalent of N₂, starts with solid 316 stainless steel rod. The shunt is sized to have a close tolerance fit to the main flow passage and is gently press fitted into the base. The solid shunt may then have one or more flats machined along its lateral axis to accommodate different flow ranges. The gap between the main flow passage and the flat machined on the shunt creates an alternate laminar flow passage such that the overall gas flow is split precisely between the sensor and the shunt. Starting with no flat and then increasing the number of flats and the size of the laminar shunt passageway, flow rates up to 200 sccm are achieved.

For flow rates above 200 sccm, the shunts are made so that an annular flow passage is formed between the shunt cylinder and the main flow passage. A 316 stainless steel plug with an annular spacing of 0.006"(0.15 mm) accommodates the 500 sccm flow range. Increased flow rates require larger gap dimensions. Eventually, a maximum annular gap dimension for laminar flow is obtained (~0.020"(0.5 mm)). This patented shunt technology also includes inboard sensor ports which ensure laminar flow without the turbulence associated with end effects. This unique flow geometry provides an exceedingly linear shunt.

7.6. Shunt Theory

A flow divider for a thermal mass flow transducer usually consists of an inlet plenum, a flow restriction, shunt and an outlet plenum (See Figure 7.3). Since stability of the flow multiplier is desired to ensure a stable instrument, there must be some matching between the linear volumetric flow versus pressure drop of the sensor and the shape of the volumetric flow versus pressure drop of the shunt. Most instruments employ Poiseuille's law¹ and use some sort of multi-passage device that creates laminar flow between the upstream sensor inlet and the downstream outlet. This makes the volumetric flow versus pressure drop curve primarily linear, but there are other effects which introduce higher order terms.

Most flow transducers are designed such that the outlet plenum has a smaller diameter than the inlet plenum. This eases the insertion and containment of the shunt between the sensor inlet point and the sensor outlet point. If the shunt is removed, the energy of the gas must be conserved when passing from the inlet plenum to the outlet plenum. From Bernoulli's equation², the sum of the kinetic energy and the pressure at each point must be a constant. Since all of the pressure drops are small, it can be assumed that the flow is incompressible.

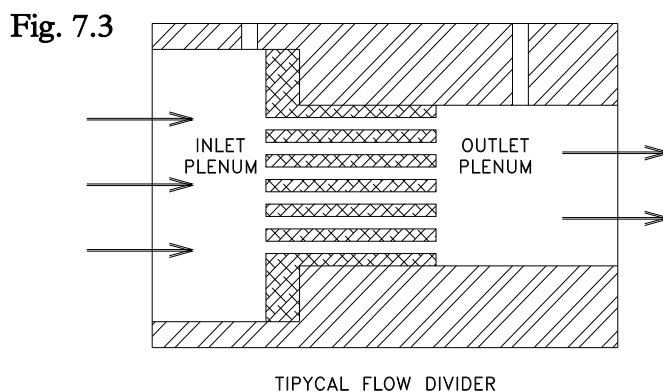

The pressure drop over the shunt can be shown to be:

$$\Delta P_a = \frac{1}{2} \rho V_i^2 \left[\left(\frac{D_i}{D_o} \right)^4 - 1 \right] \quad (7.3)$$

We can see that even with no effect from the shunt there will be a pressure drop between the sensor inlet and outlet points. This pressure drop will be a strong function of the ratio of the two diameters. Since the drop is a square function of the flow velocity the differential pressure will be non-linear with respect to flow rate. Note also that the pressure drop is a function of density. The density will vary as a function of system pressure and it will also vary when the gas composition changes. This will cause the magnitude of the pressure drop due to the area change to be a function of system pressure and gas composition.

Most of the shunts used contain or can be approximated by many short capillary tubes in parallel. From Rimborg³, we know that the equation for the pressure drop across a capillary tube contains terms that are proportional to the square of the volumetric flow rate. These terms come from the pressure drops associated with the sudden compression at the entrance and the sudden expansion at the exit of the capillary tube. The end effect terms are a function of density which will cause the quadratic term to vary with system pressure and gas composition. The absence of viscosity in the second term will cause a change in the relative magnitudes of the two terms whenever the viscosity of the flowing gas changes.

$$\Delta P = \frac{128\mu L Q}{\pi D^4} + \frac{8\rho Q^2}{\pi^2 D^4} (K_c + K_e) \quad (7.4)$$

The end effect, for a typical laminar flow element in air, accounts for approximately 4% of the total pressure drop. For hydrogen, however, which has a density that is about 14 times less than air and has a viscosity that is much greater than air, the second term is completely negligible. For the heavier gasses such as sulfur hexafluoride which has a density 5 times that of air, the end effects will become 10% of the total. These changes make it impossible to accurately calibrate an instrument on one gas and use it for another gas.

The pressure drop is linear with respect to the volumetric flow rate between a point that is downstream of the entrance area and another point further downstream but upstream of the exit region. From Kays & Crawford⁴, that entrance length (L_e) of a capillary tube in laminar flow is a function of the Reynolds number and the tube diameter. It can be shown that:

$$L_e = \frac{Q\rho}{5\pi\mu} \quad (7.5)$$

For a typical flow divider tube the entry length is approximately 0.16 cm. From this it can be seen that if the sensor inlet pickup point is inside of the flow divider tube but downstream of the entrance length and if the sensor outlet point is inside the flow divider tube but upstream of the exit point then the pressure drop that drives the flow through the sensor would be linear with respect to volumetric flow rate. Since the pressure drop across the sensor now increases linearly with the main flow rate and the sensor has a linearly increasing flow with respect to pressure drop, there is now a flow through the sensor which is directly proportional to the main flow through the flow divider, without the flow division errors that are present when the sensor samples the flow completely upstream and downstream of the flow divider.

Unfortunately, a typical shunt has an internal diameter on the order of 0.3 mm. This is too small to insert tap points into the tube. Also, the sample flow through the sensor is approximately 10 sccm while the flow through a shunt is approximately 25 sccm. This means the sample flow would be affecting the flow it was trying to measure. If the sensor tube is made large enough, and with enough flow through it to insert the sensor taps at these positions, then the pressure drop would be too small to push the necessary flow through the sensor tube.

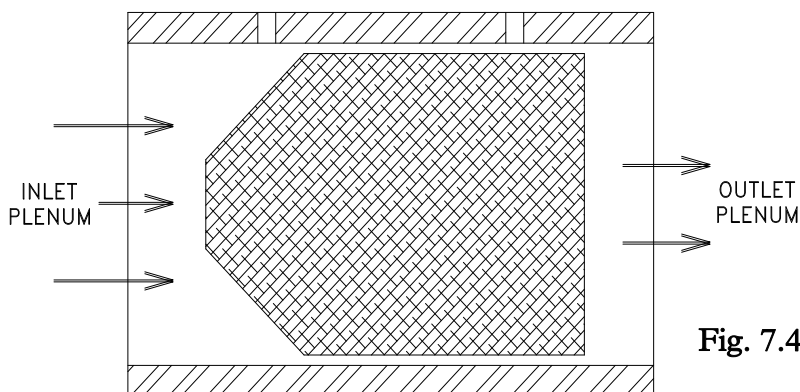

Fig. 7.4

The solution is to use a different geometry for the flow tube. It must be large enough

to allow the sample points in the middle yet with passages thin enough to create the differential pressures required for the sensor. An annular passage meets these requirements.

The basic operation is similar to the operation of the tubular shunt but the equations for the entry length and pressure drop will be different. If we assume that the annular region is very small, ($\Delta r \ll r$) :

$$c_f = \frac{24}{\text{Re}} \quad (7.6)$$

Then it can be shown that the pressure drop is:

$$P_i - P_o = \frac{12Q\mu}{\pi r(\Delta r)^3} \quad (7.7)$$

The shunt must generate a pressure drop at the desired full scale flow which drives the proper flow through the sensor tube to generate a full scale output from the sensor. Since the full scale flow of the sensor is the same for all of the different full scale flows that may pass through the shunt, the geometry must vary for the different full scale flows in order to generate the same pressured drop for all of them. From Equation 7.7 it can be seen that if the width of the annular ring is varied slightly, it can correct for very large changes in the full scale flow rate (Q).

Below is a graph showing how the thickness of the annular ring must be changed to create a passage that will properly divide the flow for various full scale flows. This graph is based on the 75 Pa pressure drop required to push full scale flow through a particular sensor that has 2 cm spacing between the inlet and outlet taps. The flow divider has an outside diameter of 0.95 cm.

Fig. 7.5 Thickness of the annular ring as a function of flow rate for a sensor with a 75 Pa drop and a 2 cm spacing.

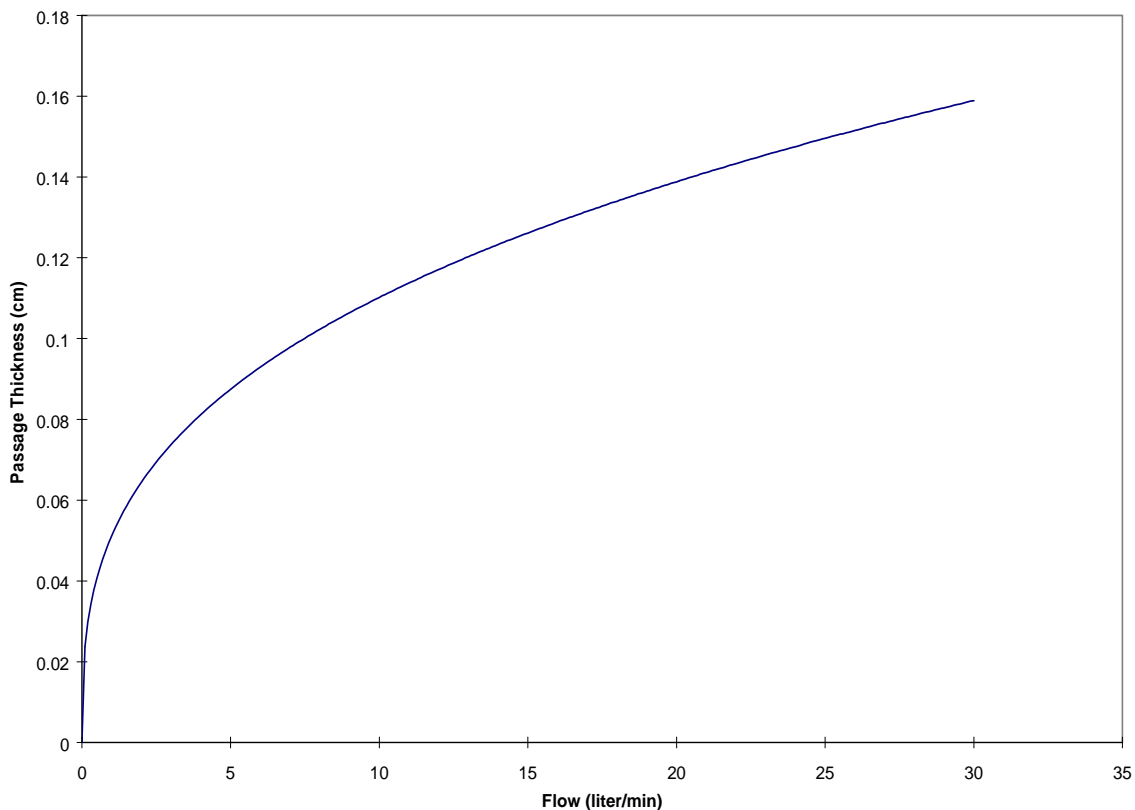

Each shunt must have a section of the annular region upstream of the upstream sensor tap to allow the flow to become fully developed before reaching the first tap. The entry length for the annular passage is then:

$$L_e = \frac{Q\rho(\Delta r)}{40\pi\mu} \quad (7.8)$$

Thickness of the annular ring as a function of flow rate for a sensor with a 75 Pa drop and a 2 cm spacing.

Below is a graph that demonstrates the entry length that would be required to design a flow divider for various full scale flows. The parameters on the sensor that the flow divider must match are the same as the ones on the previous graph.

**Entrance length as a function of flow rate
for an annular ring of the size specified in figure 7.5.**

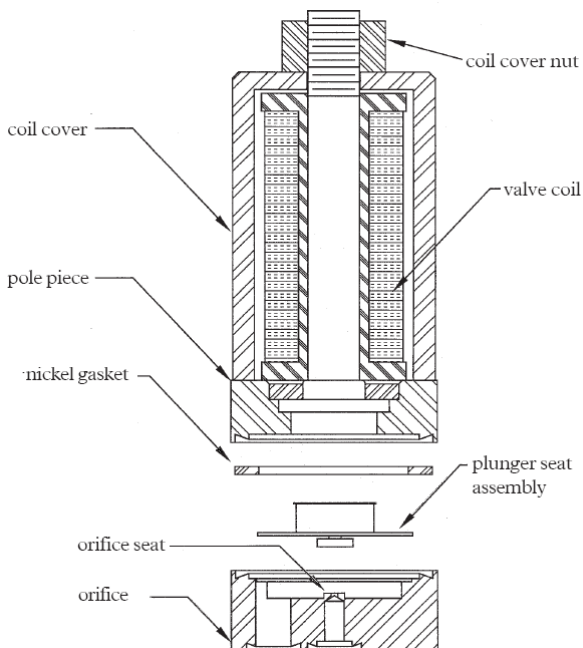
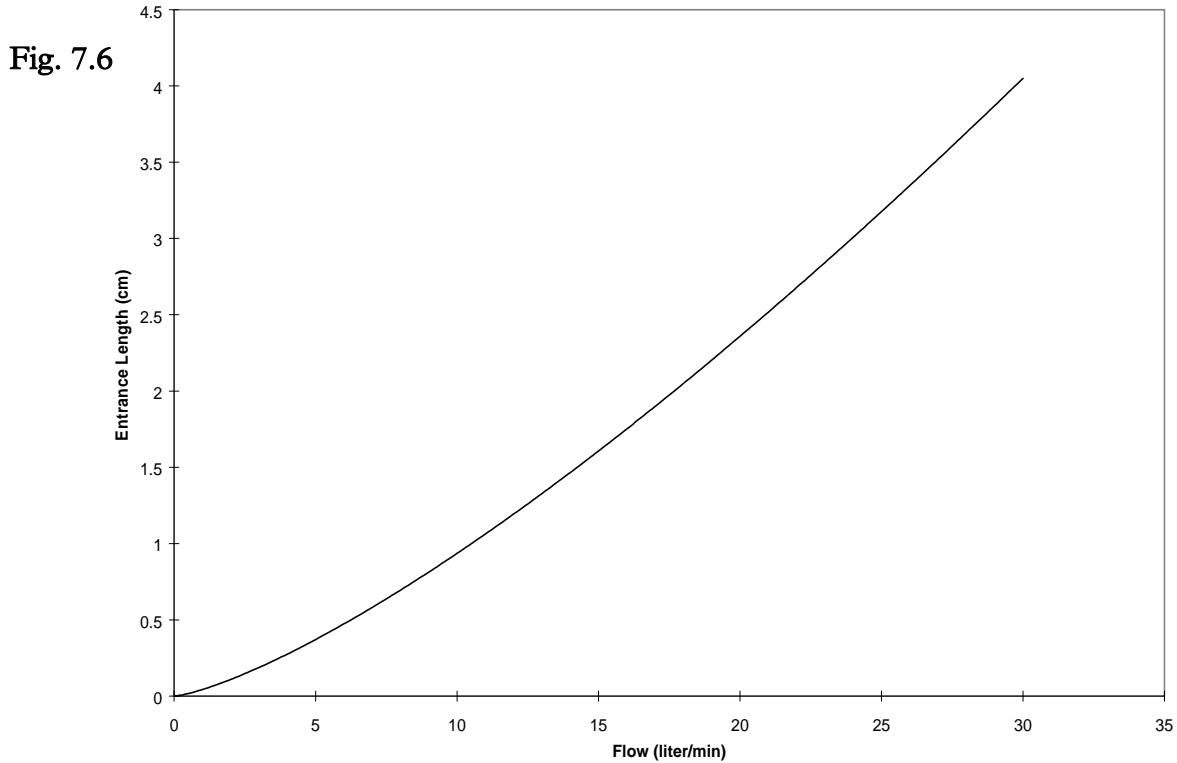

7.7 Control Valve

The control valve is an “automatic metering solenoid” valve (see Figure 7.7). While most solenoid valves operate in either the fully open or closed positions, the automatic metering solenoid valve is designed to control flow rate. A spring is used to hold a magnetic plunger assembly tightly against an orifice, thereby shutting off the flow. The magnetic plunger assembly is surrounded by a coil of magnet wire. When the coil is energized the electric current passing through the wire coil produces a magnetic field which attracts the plunger. The plunger assembly moves away from the orifice allowing the gas flow to pass between the orifice and the plunger seat.

The distance between the orifice and the plunger seat, and thus the flow through the valve, is controlled by the amount of current supplied to the coil.

The valve seat is made of Kalrez (or equivalent) perfluoroelastomer. The valve orifice is made from 316 SS. The valve plunger and pole piece are made of nickel plated magnetic alloy (Hi-perm 49) and the control springs are made of 302 stainless steel. Nickel gaskets seal all interfaces between the process gas and the outside environment.

7.8 Electronic Circuitry

The Metaline employs a thermal transfer principle (capillary tube described in section 7.2) to measure the flow through the sensor which is proportional to the total flow through the instrument.

The sensor develops a differential voltage output signal proportional to flow, which is amplified to produce 5 VDC at full scale flow. The amplified output can be measured on the external "D" connector. If a Hastings power supply is employed, the 5 volt output is also sent to the terminals on the back and to the decoding circuitry in the display. The optional 4-20 mA analog output is available in lieu of an output voltage. The addition of a 4-20 mA current loop transmitter on a secondary PC board (mounted parallel to the main pc board) is required to provide this current loop. A jumper change is made on the secondary PC board to establish the selected output mode.

8. Maintenance

8.1. Authorized Maintenance

With proper care in installation and use, the flow meter will require little or no maintenance. If maintenance does become necessary, most of the instrument can be cleaned or repaired in the field.

Some procedures may require recalibration. Do not attempt these procedures unless facilities are available. Entry into the sensor or tampering with the printed circuit board will void warranty. Do not perform repairs on these assemblies while the unit is still under warranty.

8.2. Troubleshooting

8.2.1. Sensor Related Problems

Symptom: Non-repeatable zero or span (units drifts).

Cause: A non-repeating zero or span is usually caused by a faulty or “cold” sensor.

Action: Follow the steps below to verify a repeatable zero or span. If the below steps fail to verify a repeatable zero or span, it most likely necessary to replace the sensor.

Allow full-scale flow through the instrument for two minutes.

Record full-scale flow output.

Shut off flow supply upstream to the instrument and wait two minutes.

After flow falls below 1% of full-scale, record the zero flow output.

Zero the instrument if necessary

(consult the Hastings manual for adjustment specifications).

Repeat steps 1 & 2 until no further adjustments are needed and repeatability can be verified.

Symptom: Intermittent or “noisy” output from instrument. Output changes with tapping on the sensor module.

Cause: An intermittent or “noisy” output can be caused by a bad thermocouple junction to the sensor header.

Action: Check the resistance between the center pins and the four corner pins of the large connector should be symmetric.

Check the resistance from pins 1 to 2, and 3 to 4 of the sensor module.

These pins should read 1650 ohms nominal resistance.

Also, check that the resistance from pins 5 to 6, and 7 to 8 are reading 400 ohms nominal resistance.

Incorrect resistance values indicate that the sensor needs to be replaced.

Symptom: Sensor has proper resistance readings, but little or no output with flow.

Cause: Plugged sensor.

Action: Shut off gas supply and disconnect the power to the flow meter. Remove cover and PC board from unit. Remove and inspect sensor. If sensor has evidence of clogging, clean or replace as applicable.

* Note: Be careful not to confuse a non-repeating or intermittent output with an unstable flow controller. If possible, run a flow controller as a flow meter to isolate these two problems.

8.2.2. Valve Operation

Steps for Valve Check

Rigorous valve testing is accomplished at Teledyne Hastings Instruments using trained technicians operating automated equipment that produce a variety of different command scenarios. Though it may not be possible to reproduce the exact conditions as those at Hastings Instruments, understanding the principles behind the tests will help to reproduce the conditions as closely as possible so that valve stability can be, to some degree, tested in the field.

As mentioned above, the principle object is to exercise the valve using different command change scenarios. At each change of command, the valve’s behavior is monitored for steady change and stability in control.

Audible detection is possible for slower, gross valve misbehavior but rapid oscillations of small amplitude may require the measurement of valve voltage, voltage/current readings from the sensor, flow readings via a reference flow meter or other technique. The more difficult the oscillation is to detect, the more sophisticated the equipment used to measure it must be. Such conditions preclude field testing.

Each set of command change scenarios are intended to be performed twice. The set of commands is performed once at minimum upstream pressure and maximum downstream pressure (minimum dP). Then, again at maximum upstream pressure and minimum downstream pressure (maximum dP).

- Zero the instrument under test. This assumes a leak free system.
- Command the instrument to flow 100% of full-scale.
Check for stability. Flow should reach its maximum and remain steady.
- Wait 20 seconds and command instrument to zero.
Running the valve wide open heats the valve up. The test is to be sure that the valve will still close completely after its parts have reached operating temperature. There should be no detectable leak through the valve when it is in the closed position.
- Command the instrument to 105%
It should be possible to over-range the valve without oscillating.
- Command the instrument back to 100%.
The valve should be able to return to a control state after being in an over ranged condition without oscillating.
- Command the instrument to zero and wait for 20 seconds.
- Command the instrument to 10% of full-scale flow.
The valve should be able to open from a fully closed condition without oscillating. Do not confuse the initial hunt for the set-point as unnatural oscillation. Every PID control loop has an initial over- and undershoot before settling in on its target level.
- Introduce a variety of step changes ranging from a high set-point to a lower one as well as from lower set-points to higher ones. Next try mid-range set-points to higher set-point and mid-ranged set-points to lower set-points.
With each step change in command, the unit should change flow rate steadily and it should not oscillate

The absolute valve voltage at 100% of flow should be 30000 counts (v 27) and the absolute minimum valve voltage at 10% of flow should be 6000 counts (v 27).

Symptom: Valve does not open.

Cause: Blocked flow passages, or excessively high valve voltage.

Action: General Checks:

Inspect pilot and main seat assembly for blocked passages.

Check the valve coil leads for nicks and cuts and verify that the coil is properly plugged into the controller card.

Check the valve coil, the resistance of the coil should be around 320 to 370 ohms.

High Valve Voltage:

A high valve voltage can cause the valve to fail to open. The best way to adjust the valve assembly for a lower valve voltage is to change the configuration of the control springs.

Please refer to the table below for control spring configuration styles.

Usually setting up the control springs in a “spiral” configuration generates the lowest valve voltage, but also the least amount of stability.

Setting the control springs up in an “S” style configuration generates a moderate valve voltage and moderate stability.

Finally setting the control springs in a “crossed” style configuration generates the highest valve voltage and the most stability.

8.2.3. Valve Control Spring Configuration Styles

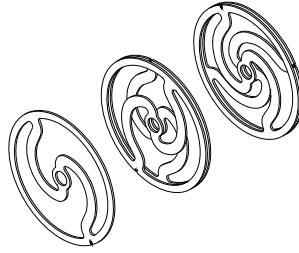

Symptom: Valve does not achieve complete shut off.

Cause: Orifice/diaphragm leak, low DP spring with improper tension, occluded bleed screw, or seat assembly/pilot orifice leak.

Action: Diaphragm/ Main orifice leak:

Sometimes the valve will leak through the diaphragm where the seat and main orifice meet.

Visually inspect the diaphragm seat and main orifice for nicks, scratches and gouges and replace any parts that do not have a smooth sealing surface.

Occasionally the main orifice gasket will get cut due to over tightening, replace the gasket if necessary and reinstall the orifice hand tight.

Low DP Spring:

The low DP spring can often cause a valve to fail to completely close. The unloaded spring length should be 0.50". This can be achieved by slightly stretching the spring. Be sure not to over stretch the spring. If more tension is needed to ensure complete closure of the valve a second low DP spring can be added to the first by weaving the two springs into each other.

Occluded bleed screw:

A partially occluded bleed screw can cause sluggish or partial operation. Remove the bonnet, then the bleed screw.

Inspect the bleed screw for a small burr in the inlet or outlet of the bleed screw tube.

Clear out any obstructions as necessary.

Seat assembly/ pilot orifice leak:

Adjust the pilot valve seat for good closure. This is a common cause for non-operating valves.

Use small 0.001" (part# 38-1-106) shims between the control spring and the pilot seat to adjust the pilot seat toward the orifice.

This adjustment can sometimes be made by adjusting the control springs of the seat assembly into a stiffer configuration along with the placement of small shims.

8.2.4. Problems with Operation

Symptom: Flow meter reads other than 0.00 VDC with no flow or there is a small flow when the flow meter reads 0.00 VDC.

Cause: Zero pot is out of adjustment.

Action: Shut off all flow. For the standard 0-5VDC output, re-zero with the "zero" command or adjust the zero potentiometer until the meter indicates zero.

Symptom: Flow meter is out of calibration and non-linear.

Cause: Leaks in the gas inlet or outlet fittings.

Action: Check all fittings for leaks by placing soap solution on all fittings between gas supply and final destination of gas. Check flow meter for leaks. Replace if required or recalibrate as necessary.

Symptom: Little or no flow, even when the valve is OPEN.

Cause: Blocked orifice or incorrect pressure across the flow controller

Action: Verify that the pressure drop originally specified on the instrument is across the instrument. If the differential pressure across the instrument is correct, the orifice may be obstructed. Remove all gas pressure and shut off power supply. Remove the valve

Symptom: Output reads strong indication of flow with no flow present. Zero pot has no effect.

Cause: Power shorted out.

Action: Turn power supply off for a few seconds, and then turn it on again. If this is ineffective, disconnect the power supply from the unit. Check that the power supply voltages are correct. Incorrect voltages most likely signify a faulty regulator chip inside the supply. If the power supply display returns to zero after the instrument has been disconnected there may be a short from the unit to ground.

Symptom: Digital 300 continues to indicate flow with no flow present, or indicates ± 14 volts. Power supply inputs are correct (see the above troubleshooting tip) and zero pot has no effect.

Cause: Faulty IC chip(s) on the main PC board.

Action: Replace main PC board.

Symptom: Output of flow meter is proportional to flow, but extremely small and not correctable by span pot.

Cause: Sensor is not being heated.

Action: Shut off gas supply and disconnect the power to the flow meter. Remove cover and PC board from unit. Check the resistance from pins 1 to 2, and 3 to 4 (refer to figures in section 6) of the sensor module. These pins should read 1650 Ω nominal resistance. Also check that the resistance from pins 5 to 6, and 7 to 8 are 400 Ω nominal values. Incorrect resistance values indicate that the sensor unit needs to be replaced.

Symptom: Slight errors are observed in flow vs. command when analog inputs are in use.

Cause: Analog inputs A/D converters need adjustment.

Action: Adjust analog input factors.

- a. Change MFC Config for analog commands if not already selected (v 2 =x81).
- b. With a calibrated power supply, send a 5 VDC (6.5 mV) to the UIT.
- c. Adjust the analog input #1 (s 27) read 5VDC by changing the value of s 25.
- d. Send a zero command from the power supply.
- e. Adjust analog input #0 (s 69) to read 0mV by changing the value of s 24.
- f. Repeat steps two through four until no adjustment is necessary.

8.2.5. PCB Troubleshooting

Before you begin:

- a. Check for bad solder joints or shorts on or between components and burnt parts.
- b. Check that all connections are properly being made.
- c. Verify power supply.
- d. Check and verify that the sensor is good before troubleshooting a meterboard by checking the resistance between the center pins and the four corner pins of the large connector. These should be symmetric. Check the resistance from pins 1 to 2, and 3 to 4 of the sensor module. These pins should read 1650 ohms nominal resistance. Also, check that the resistance from pins 5 to 6, and 7 to 8 are reading 400 ohms nominal resistance. Incorrect resistance values indicate that the sensor needs to be replaced.

Troubleshoot PCB's with out valve coils or option cards to isolate problems.

8.2.6. 0-5 VDC or 0-10 VDC output option

Symptom: Output reads -13 VDC at zero flow (PC-871)

Cause: Faulty op-amp, DAC, or diode in analog output circuit.

Action: Measure the VDC on the cathode side of diode D411 & D413.

Expect +14 VDC (D411) and -14VDC (D413). If the value is other than expected, replace that diode.

If the problem persists, replace transformer T401.

If values at D411 & D413 are correct, check the voltages at pin 5 of U404.

Expect 2.5 VDC (VREF). If incorrect voltage is observed, the problem is elsewhere in the circuit.

Check the voltage at pin1.

Expect 0 VDC +/- a few mV. If pin 5 is correct but pin 1 is not, replace U404. If both are correct, check the voltage on pin 7 of U403. If output at pin 7 of U403 is more the a few mV replace U403. If none of the items above resolve issue replace the PCB.

8.3. End Cap Removal

The end cap on the inlet side must be removed to gain access to shunt assembly. First remove power and shut off the supply of gas to the instrument. Disconnect the fittings on the inlet and outlet sides of the transducer and remove it from the system plumbing. Remove the four Allen head screws holding the end cap to the instrument. Carefully remove the end cap, spring, and shunt, noting their order and proper orientation. The shunt can be severely damaged if dropped. Examine the shunt. If damaged, dirty or blocked, clean and replace as applicable.

Reassemble in the reverse order of disassembly. Recalibration of the 300 Series is necessary.

Reassemble in the reverse order of disassembly. Recalibration of the 300 Series is necessary.

9. Volumetric Vs. Mass Flow

Mass flow measures just what it says, the mass or number of molecules of the gas flowing through the instrument. Mass flow (or weight per unit time) units are given in pounds per hour (lb/hour), kilograms per sec (kg/sec) etc. When your specifications state units of flow to be in mass units, there is no reason to reference a temperature or pressure. Mass does not change based on temperature or pressure.

However, if you need to see your results of gas flow in volumetric units, like liters per minute, cubic feet per hour, etc. you must consider the fact that volume DOES change with temperature and pressure. To do this, the density (grams/liter) of the gas must be known and this value changes with temperature and pressure.

When you heat a gas, the molecules have more energy and they move around faster, so when they bounce off each other, they become more spread out, therefore the volume is different for the same number of molecules.

Think about this:

The density of Air at 0°C is 1.29 g/liter

The density of Air at 25°C is 1.19 g/liter

The difference is 0.1 g/liter. If you are measuring flows of 100 liters per minute, and you don't use the correct density factor then you will have an error of 10 g/minute!

Volume also changes with pressure. Think about a helium balloon with a volume of 1 liter. If you could scuba dive with this balloon and the pressure on it increases. What do you think happens to the weight of the helium? It stays the same. What would happen to the volume (1 liter)? It would shrink.

Why is the word standard included with the volume terms liters and cubic feet in mass flow applications?

A mass flow meter measures mass ...and we know we can convert to volume.

To use density we must pick one (or standard) temperature and pressure to use in our calculation. When this calculation is done, the units are called standard liters per minute (SLM) or standard cubic feet per minute (SCFM), for instance, because they are referenced to a standard temperature and pressure when the volume is calculated.

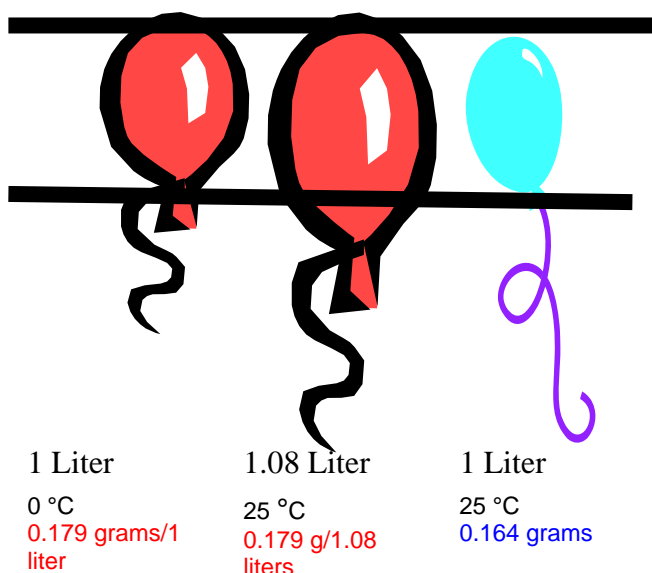

Using the example to the left, we can see a standard liter can be defined differently. The first balloon contains 0.179 grams of Helium at 0 °C and 760 Torr (density of 0.179 grams/liter). Heat up that balloon to room temperature and the volume increases, but the mass has not changed. The volume is not 1 liter anymore, it is 1.08 liters.

So, to define a standard liter of Helium at 25 °C, we must extract only one liter from the second balloon and that liter weighs only 0.175 grams.

If a mass flow meter is set up for STP at 0 °C and 760 Torr, when it measures 0.179 grams of He, it will give you results of 1 SLM. If a second meter is set up for STP at 25 °C and 760 Torr, when it measures 0.164 grams, it will give results of 1 SLM.

10. Gas Conversion Factors

Gas conversion factors (GCF's) for gasses metered using Hastings Instruments products, can be found by visiting the Hastings Instruments web site. The web address can be found at the end of this document. The gas conversion factors (GCF's) provided by Hastings Instruments (HI) fall into five basic accuracy domains that, to a large extent, are dependent on the method by which they are found. The following table summarizes the different methods used to determine the GCF's. The table lists the methods in decreasing order of the degree of accuracy that may be achieved when applying a conversion factor.

Methods Used to Determine Gas Conversion Factors

1. Determined empirically at Hastings Instruments
2. Calculated From NIST tables
3. Calculated using the virial coefficients of independent investigators' empirical data using both temperature and pressure as variables.
4. Calculated from virial coefficients using temperature only.
5. Calculated from specific heat data at 0° C and 1 atmosphere

1. The most accurate method is by direct measurement. Gases that can be handled safely, inert gases, gases common in the atmosphere, etc., can be run through a standard flow meter and the GCF determined empirically.

2. The National Institute of Standards and Technology (NIST) maintains tables of thermodynamic properties of certain fluids. Using these tables, one may look up the necessary thermophysical property and calculate the GCF with the same degree of accuracy as going directly to the referenced investigator.

3 and 4. Many gases that have been investigated sufficiently by other researchers, can have their molar specific heat (C_p) calculated. The gas conversion factor is then calculated using the following ratio.

$$GCF = \frac{C'_{pN2}}{C'_{pGasX}}$$

GCF's calculated in this manner have been found to agree with the empirically determined GCF's within a few tenths of a percent. Data from investigations that factor in pressure as well as temperature, usually supply a higher degree of accuracy in their predictions.

5. For rare, expensive gases or gases requiring special handling due to safety concerns, one may look up specific heat properties in a variety of texts on the subject. Usually, data found in this manner applies only in the ideal gas case. This method yields GCF's for ideal gases but as the complexity of the gas increases, its behavior departs from that of an ideal gas. Hence the inaccuracy of the GCF increases.

Hastings Instruments continually searches for better estimates of the GCF's of the more complex gases and regularly updates the list.

Most Hastings flow meters and controllers are calibrated using nitrogen. The conversion factors published by Hastings are meant to be applied to these meters. To apply the GCF's, simply multiply the gas flow reading and the GCF for the process gas in use. For example, to calculate the actual flow of argon passing through a nitrogen-calibrated meter that reads 20 sccm, multiply the reading and the GCF for argon.

$$20 \times 1.4047 = 28.094$$

Conversely, to determine what reading to set a nitrogen-calibrated meter in order to get a desired flow rate of a process gas other than nitrogen, you divide the desired rate by the GCF. For example, to get a desired flow of 20 sccm of argon flowing through the meter, divide 20 sccm by 1.4047.

$$20 / 1.4047 = 14.238$$

That is, you set the meter to read 14.238 sccm.

Some meters, specifically the high flow meters, are calibrated in air. The flow readings must be corrected for the case where a gas other than air is flowing through the meter. In addition, there must be a correction for the difference in the GCF from nitrogen to air. In this case, multiply the reading and the ratio of the process gas' GCF to the GCF of the calibration gas. For example, a meter calibrated in air is being used to measure the flow of propane. The reading from the meter is multiplied by the GCF for propane divided by the GCF of air.

$$20 * (0.3499/1.0015) = 6.9875$$

To calculate a target setting (20 sccm) to achieve a desired flow rate of propane using a meter calibrated to air, invert the ratio above and multiply.

$$20 * (1.0015/0.3499) = 57.2449$$

Gas conversion factors can be found at the Hastings Instruments web site.

<http://www.teledyne-hi.com>

Follow the link to Mass Flow Products and then to Gas Conversion Factors.

11. References

1. Bermand, Armand, 1990, .Vacuum engineering calculations, formulas, and solved exercises., Academic Press, San Diego
2. Bernoulli, Daniel., Bernoulli, Johanne., 1968 .Hydro-dynamics., Dover Publications, New York
3. Rimberg, D. .Pressure Drop Across Sharp-end Capillary Tubes., I&EC Fundamentals, vol.6, no. 4, November 1967
4. Kays, W. M., Crawford M. E., 1993, .Convective Heat and Mass Transfer., 3rd edition, McGraw-Hill, New York

12. Warranty and Repair

12.1. Warranty Repair Policy

Hastings Instruments warrants this product for a period of one year from the date of shipment to be free from defects in material and workmanship. This warranty does not apply to defects or failures resulting from unauthorized modification, misuse or mishandling of the product. This warranty does not apply to batteries or other expendable parts, or to damage caused by leaking batteries or any similar occurrence. This warranty does not apply to any instrument which has had a tamper seal removed or broken.

This warranty is in lieu of all other warranties, expressed or implied, including any implied warranty as to fitness for a particular use. Hastings Instruments shall not be liable for any indirect or consequential damages.

Hastings Instruments, will, at its option, repair, replace or refund the selling price of the product if Hastings Instruments determines, in good faith, that it is defective in materials or workmanship during the warranty period. Defective instruments should be returned to Hastings Instruments, **shipment prepaid**, together with a written statement of the problem and a Return Material Authorization (RMA) number.

Please consult the factory for your RMA number before returning any product for repair. Collect freight will not be accepted.

12.2. Non-Warranty Repair Policy

Any product returned for a non-warranty repair must be accompanied by a purchase order, RMA form and a written description of the problem with the instrument. If the repair cost is higher, you will be contacted for authorization before we proceed with any repairs. If you then choose not to have the product repaired, a minimum will be charged to cover the processing and inspection. Please consult the factory for your RMA number before returning any product repair.

TELEDYNE HASTINGS INSTRUMENTS
804 NEWCOMBE AVENUE
HAMPTON, VIRGINIA 23669 U.S.A.
ATTENTION: REPAIR DEPARTMENT

TELEPHONE (757) 723-6531
TOLL FREE 1-800-950-2468
FAX (757) 723-3925
E MAIL hastings_instruments@teledyne.com
INTERNET ADDRESS <http://www.teledyne-hi.com>

Repair Forms may be obtained from the "Information Request" section of the Hastings Instruments web site.