

## High Throughput Leak Detection

### How can you improve leak testing precision and throughput?

Various methods have historically been used to check leaks in systems and components—from bubble tests to rotameters and pressure loss detection. While these traditional methods have their place, they each have serious drawbacks in accuracy, throughput, and automation. You may be faced with more demanding situations that call for more effective techniques. This note outlines a method that can more quickly detect and accurately measure leaks at controlled differential pressures. Furthermore, it enables automation (including data capture) and cycle-time efficiency.

### Objectives

- ✓ Test for and precisely measure leaks in the range from 0.1 sccm to 100 sccm with controlled pressure from 15 to 200 psig.
- ✓ Reduce the testing time from minutes to seconds.

### Method

A typical leak test stand is shown in the figure. This arrangement has a pressure controlled manifold outfitted with one or more test stations. Multiple stations allow parallel testing to improve throughput. At the start of the test, the pressure is at a constant elevated pressure throughout the manifold and the test part. When the part begins to leak, a pressure differential develops across the flow meter between the part and the manifold. While this differential allows the flow meter to measure, it also causes a delay in making an accurate measurement while the system reestablishes a steady-state pressure condition. The larger the meter's pressure drop, the longer it takes to reach a steady flow. For typical applications using a standard flowmeter it can take several minutes while the signal gradually approaches the correct flow. The tubing downstream of the flow meter also contributes to this delay and therefore should be as short as possible. Minimizing tubing length also improves reading stability by reducing thermally generated flows in the tubing. In addition to the delay, the pressure differential across the flowmeter creates an uncertainty in the actual test part pressure. This problem is made worse by the fact that the uncertainty is greater for larger leaks. For these reasons, it is essential to use a flow meter designed to operate with a very low pressure differential.

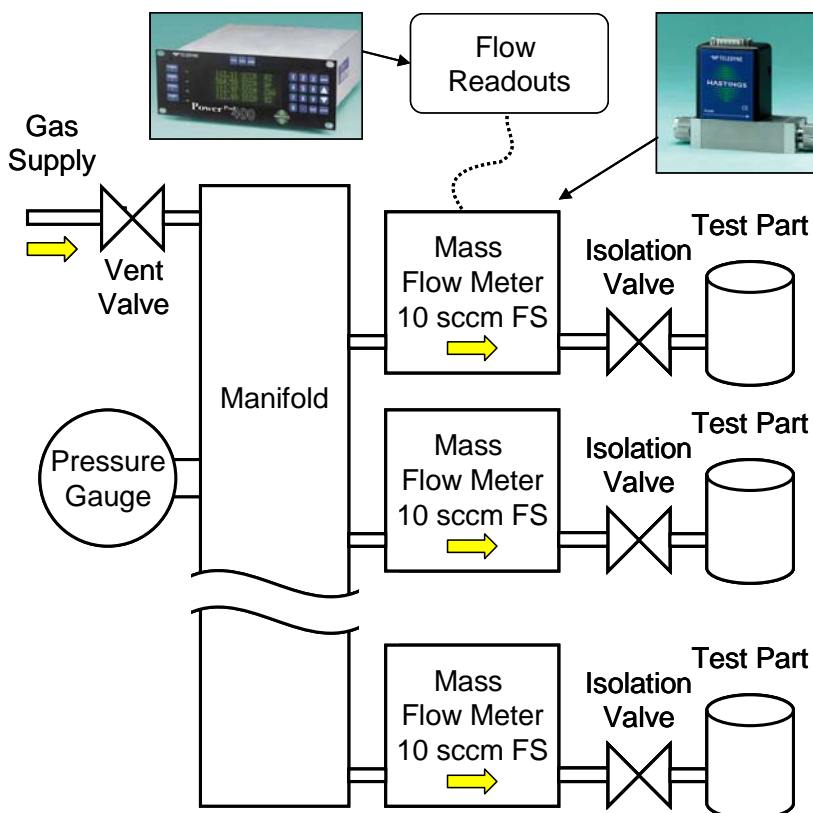

## Instrumentation Choice

The recommended mass flow meter is the Hastings HFM 300. It is chosen for its ability to accurately measure flow to within 0.75% of Full Scale while operating with extremely low pressure differential. Whereas typical mass flow meters require 4 inH<sub>2</sub>O pressure differential to operate, the HFM 300 only requires 0.25 inH<sub>2</sub>O. For your leak test, 16 times less pressure differential means 16 times faster! This is demonstrated in the actual test case below.

Another important consideration when selecting the proper instrument is avoiding what is known as “fold-over”. This problem arises in some typical flow meters when they actually misreport a very high (over-range) flow as a normal flow and allow a bad part to pass. The HFM 300’s sensor design correctly interprets over-range flows; its output signal will not come back on scale. The HFM 300 will not report false acceptable readings.

## Test Case

### Test Parameters:

Flow meter Full Scale range - 10 sccm

Volume of test part - 1 liter plus volume of tubing downstream of the flow meter

Leak rate - 10 sccm

Pressure differential of HFM 300 - 0.25 inH<sub>2</sub>O

Pressure differential of typical mass flow meter - 4 inH<sub>2</sub>O

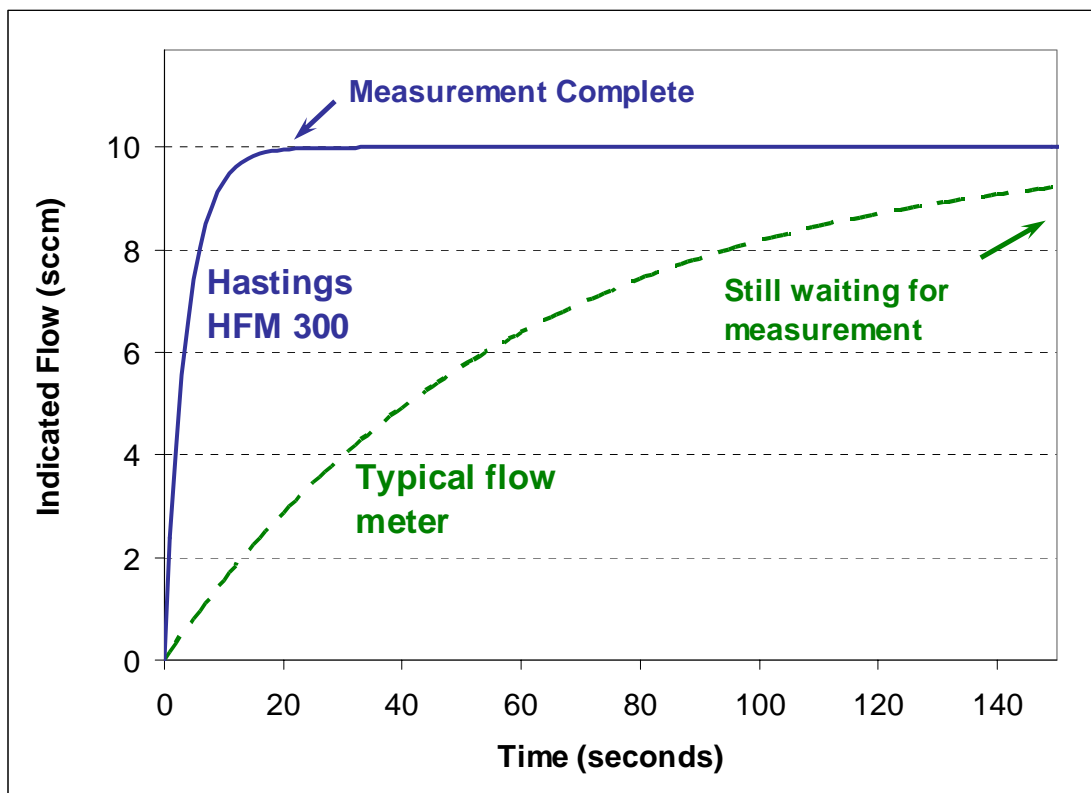

**By using the HFM 300, the time to accurately measure the leak rate (to within 2% of the final value) has been cut from over 4 minutes to just 16 seconds.**

For Information on all Teledyne Hastings Vacuum Measurement and Mass Flow Instruments, visit our website:

[www.teledyne-hi.com](http://www.teledyne-hi.com)  
or contact us at 1-800-950-2468