



# TELEDYNE HASTINGS INSTRUMENTS

*HFM-201 Flow Meter*

*HFC-203 Flow Controller*

## **MEDIUM CAPACITY FLOWMETERS AND CONTROLLERS**

- Available flow ranges:
- 0-25 slm to 0-1000 slm (N<sub>2</sub>)

### **FEATURES**

- ± 1% full scale accuracy<sup>1</sup>
- Proven reliability
- NIST Traceable Calibration Certificate

### **APPLICATIONS**

- Leak testing
- Flame Spray
- Aerospace

### **BENEFITS**

- Excellent Stability
- Proven Reliability
- Outstanding Zero Stability



*Download a free QR reader  
from your smartphone app store*

# Flow Meters and Flow Controllers



### **DESCRIPTION**

The Teledyne Hastings Instruments (THI) Model HFM Mass Flowmeter and HFC Mass Flow Controller represent a culmination of over 65 years of experience in designing and manufacturing reliable, high quality mass flow instruments.

The HFM/HFC Series of flow instruments is based on a modular design. At the heart of each instrument is an insulated thermal transfer sensor which provides enhanced zero stability. The HFC also features a two-stage, pilot-operated control valve.

All of these standard features, when coupled with the instrument's inherent linear response to flow changes and THI's long-proven reputation for quality, result in the finest flowmeters and flow controllers available today.

## Specifications and Standards

### Optional Features

- Fittings –
  - VCR®
  - VCO®
  - NPT
  - Swagelok®,
- Seals -
  - Kalrez
  - Neoprene
  - Buna-N
- Enhanced response time
- 4-20 mA converters
- Cleaned for Oxygen service

### Accessories

- Power Supplies available with;
  - Integral Flow Totalizer
  - Alarm Set Points
  - Interconnecting cables

Note: After changing components, instruments require calibration to meet accuracy specifications

### COMMON SPECIFICATIONS HFM-201/HFC-203

<b>Accuracy<sup>1</sup></b>	± 1.0% of F.S.
<b>Repeatability</b>	± 0.05% of F.S.
<b>Maximum Operating Pressure</b>	500 psi
<b>Pressure Coefficient</b>	-0.0067% /psi
<b>Leak Integrity</b>	< 1x10 <sup>-9</sup> sccs He
<b>Temperature Coefficient (zero)</b>	Zero ±.035%C of F.S. (0-60°C)
<b>Temperature Coefficient (span)</b>	Span ± .05%C of Rdg (0-60°C)
<b>Standard Output</b>	0 - 5 VDC
<b>Optional Outputs</b>	4 - 20 mA, 0 - 20 mA
<b>Connector (± 15 VDC)</b>	15 - pin subminiature D
<b>Connector (+ 24 VDC)</b>	9 - pin subminiature D

### SPECIFICATIONS HFM-201

<b>Power Requirements (±15 V)</b>	± (14-16) VDC @ ±30mA (<1 Watt)
<b>Power Requirements (+24 V)</b>	(14- 32) VDC (<1.9Watt)
<b>Wetted Materials</b>	302 SS, 316 SS, Nickel 200, Viton®
<b>Weight (approx.)</b>	201L - 3.55 lb (1.61 kg) / 201H - 3.25 lb (1.47 kg)

### SPECIFICATIONS HFC-203

<b>Power Requirements (±15 V)</b>	± (14-16) VDC @ +60/-185 mA (< 3 Watt)
<b>Power Requirements (+24 V)</b>	(14- 32) VDC (<3Watt)
<b>Wetted Materials</b>	302 SS, 316 SS, Nickel 200, Viton® Kalrez (Valve Seat)
<b>Setpoint Input</b>	0-5 VDC (Std) /4-20mA (optional)
<b>Weight (approx.)</b>	203L - 5.20 lb (2.36 kg) / 203H - 5.15 lb (2.34 kg)

<sup>1</sup> See Product Manual for critical information on instrument accuracy and the use of GCFs (gas conversion factors). Stated accuracy is for nitrogen or other gas specific calibration and use with this gas only.

Hastings Instruments reserves the right to change or modify the design of its equipment without any obligation to provide notification of change or intent to change.

Viton® is a registered trademark of DuPont Performance Elastomers  
 Kalrez® Is a registered trademark of DuPont Dow Elastomers  
 Teflon® is a registered trademark of E.I. DuPont de Nemours & Co.  
 VCR® is a registered trademark of Swagelok Company.

Outline Drawing: HFM-201 (L) Flow Meter

±15 VOLT VERSION

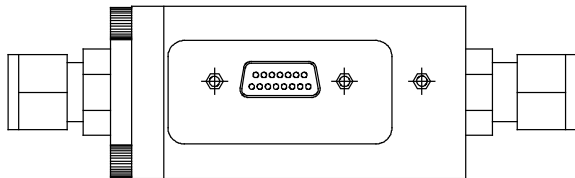

24 VOLT VERSION

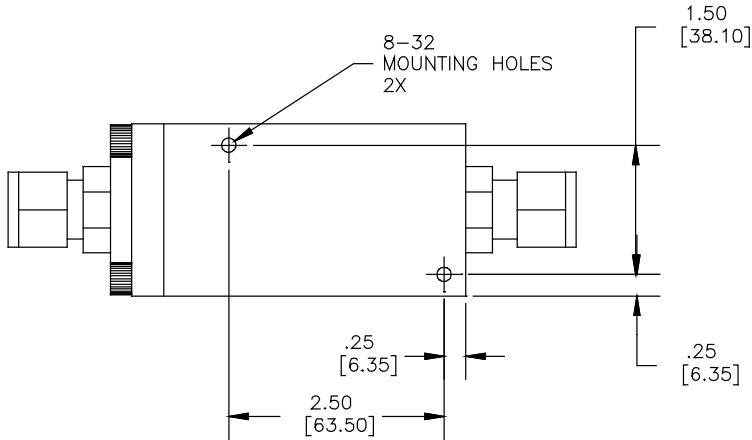
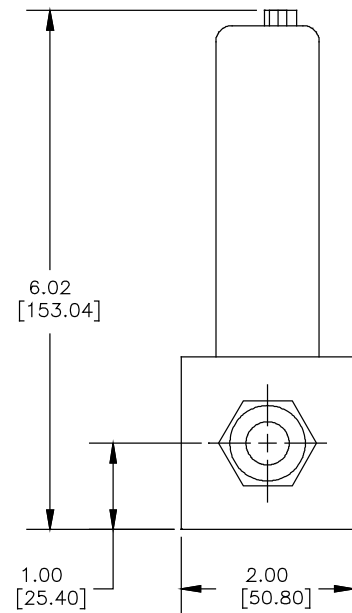
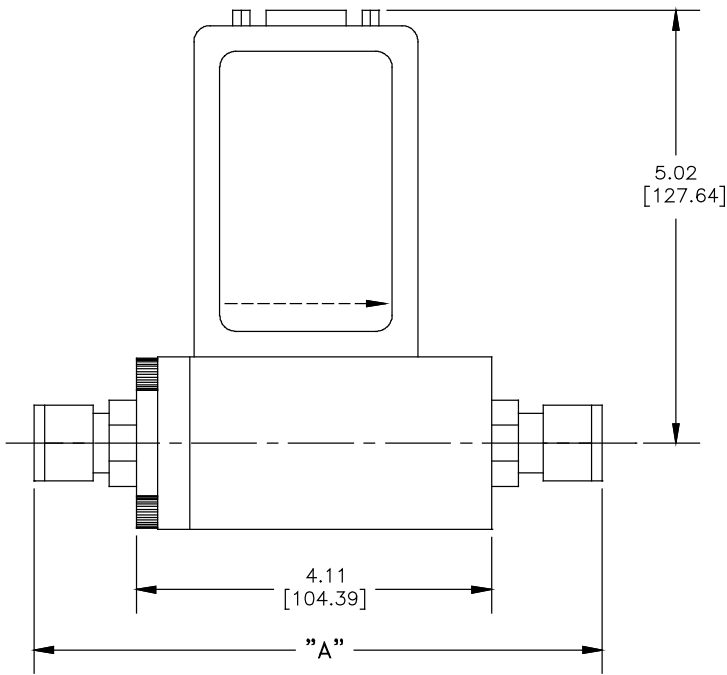
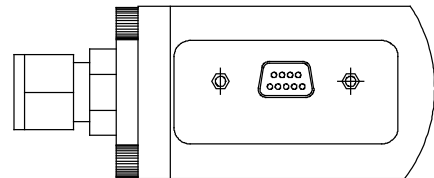

1/2" BASE SIZE

FITTING TYPE	DIM "A"
3/4"-16 FEMALE (DIM B)	4.11 [104.39]
SWAG. 1/2" W NUT	6.31 [160.27]
SWAG. 1/2" BARE	5.73 [145.54]
VCO FACE 1/2"	6.17 [156.72]
VCR FACE 1/2"	6.55 [166.37]
12mm SWAGELOK	6.55 [166.37]
10mm SWAGELOK	6.37 [161.79]
3/8" MALE NPT	6.01 [152.65]
1/2" MALE NPT	6.33 [160.78]

Outline Drawing: HFC-203 (L) Flow Controller

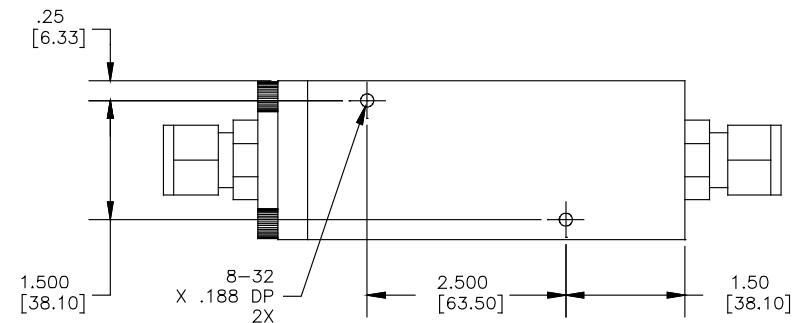
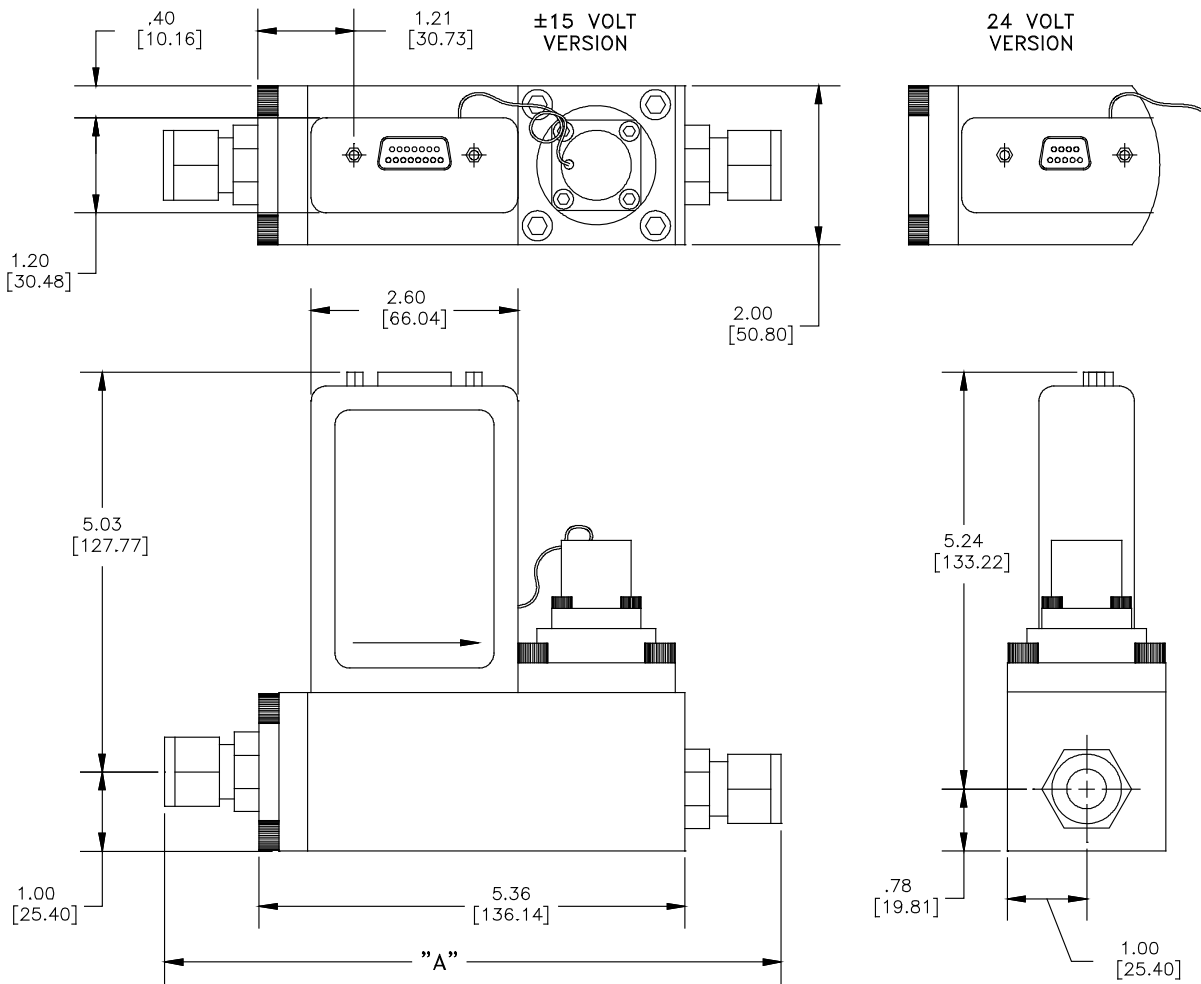

1/2" BASE SIZE

FITTING TYPE	DIM "A"
3/4"-16 FEMALE (DIM B)	5.36 [136.14]
SWAG. 1/2" W NUT	7.56 [192.02]
SWAG. 1/2" BARE	6.98 [177.29]
VCO FACE 1/2"	7.42 [188.47]
VCR FACE 1/2"	7.80 [198.12]
12mm SWAGELOK	7.78 [197.61]
10mm SWAGELOK	7.60 [193.04]
3/8" MALE NPT	7.24 [183.89]
1/2" MALE NPT	6.33 [160.78]

Outline Drawing: HFM-201 (H) Flow Meter

±15 VOLT  
VERSION

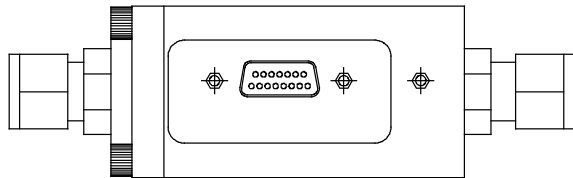

24 VOLT  
VERSION

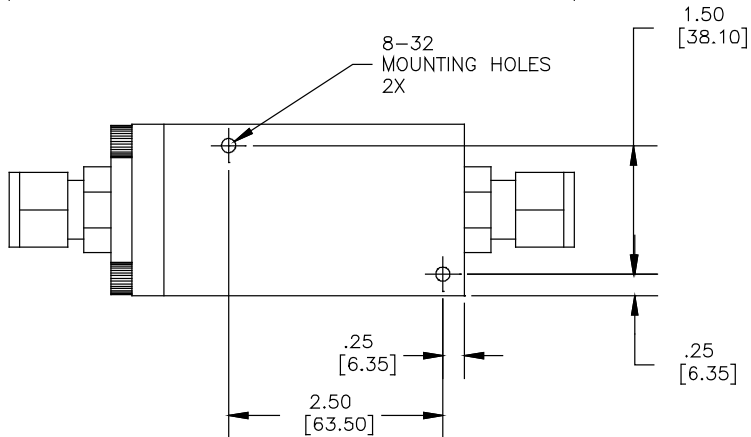
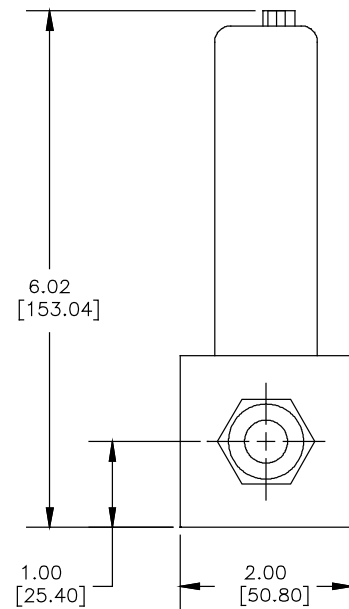
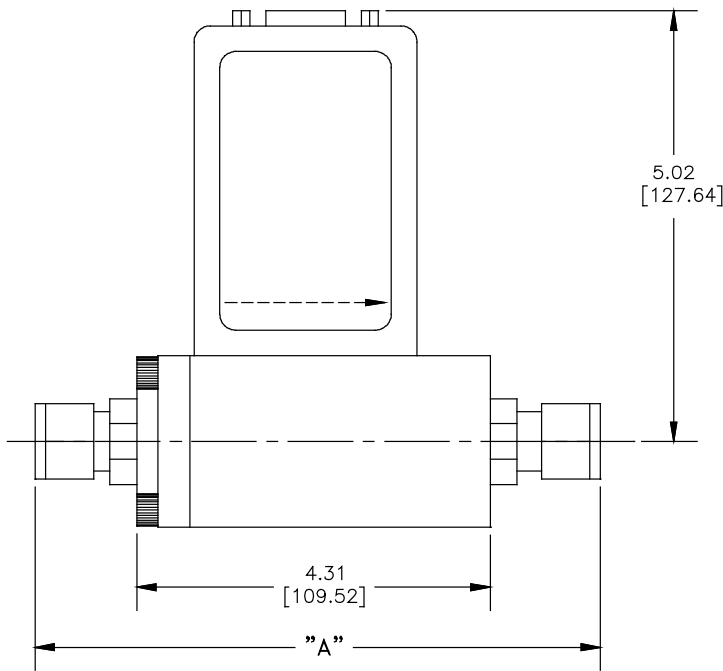
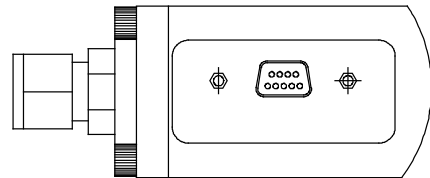

3/4" BASE SIZE

FITTING TYPE	inches-mm
1 1/16-12 FEMALE (DIM B)	4.31 [109.52]
3/4" SWAGelok	6.99 [177.60]
20mm SWAGelok	6.96 [176.83]
3/4" VCO FACE	6.59 [167.44]
3/4" VCR FACE	7.52 [191.06]

Outline Drawing: HFC-203 (H) Flow Controller

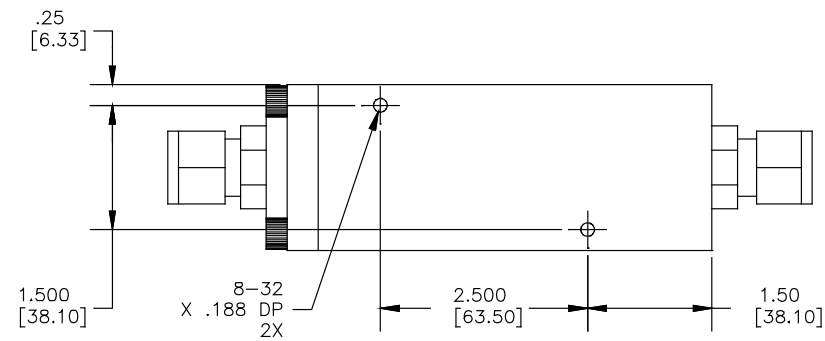
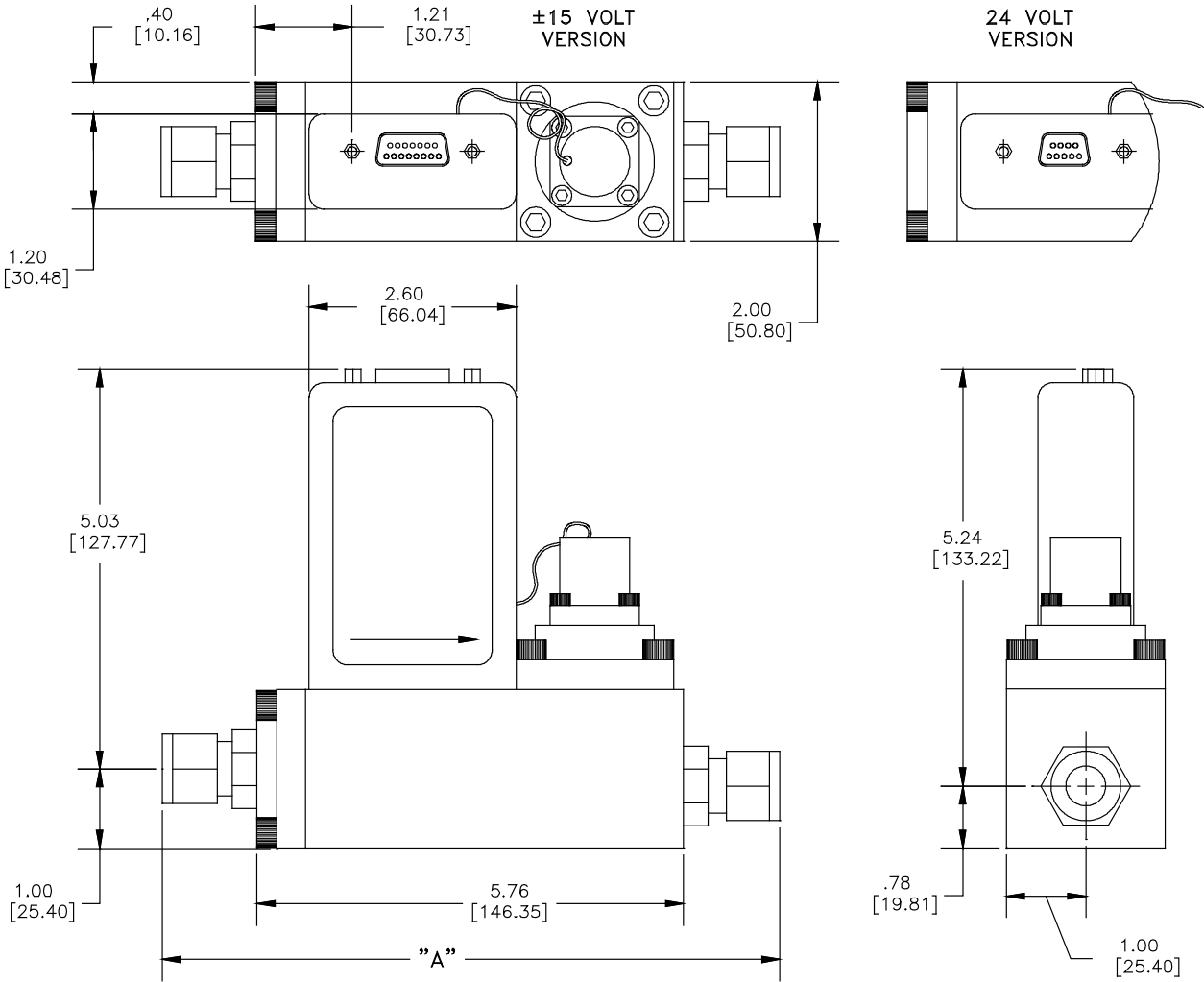

3/4" BASE SIZE

FITTING TYPE	inches-mm
1 1/16-12 FEMALE (DIM B)	5.76 [146.35]
3/4" SWAGELOK	8.44 [214.43]
20mm SWAGELOK	8.41 [213.66]
3/4" VCO FACE	8.04 [204.27]
3/4" VCR FACE	8.97 [227.89]

# Selection Chart

Model No.	Circuit Board	Output	Fittings	O - Rings	Working Pressure	Calibration Type
HFM-201 HFC-203						

Circuit Board	
01	Standard ( $\pm 15$ VDC)
03	24 VDC Supply

Output	
01	0-5 Volts (Std)
02	4-20 mA ** (Output Only)
03	4-20 mA I/O
04	0-20 mA I/O

Fittings: HFM-201L/HFC-203L	
01	1/2" Swagelok (Std)
02	1/2" VCR <sup>®</sup>
03	No Fitting, 3/4-16 MS Straig
04	1/2" VCO <sup>®</sup>
05	12 mm Swagelok
06	3/8" Male NPT
07	1/2" Male NPT
08	10 mm Swagelok

Fittings: HFM-201H/HFC-203H	
09	3/4" Swagelok (Std)
10	3/4" VCO <sup>®</sup>
11	20 mm Swagelok
12	No Fitting, 1 1/16 MS Straig
13	3/4" VCR <sup>®</sup>

O - Rings	
01	Viton (std)
02	Kalrez
03	Neoprene
04	Buna-N
05	Silicone

Working Pressure	
01	500 psig max (Std)
02	1000 psig

Calibration	
01	NIST 5 point (Std)
02	NIST 10 Point
03	NIST 20 Point
04	Curve Fit

\*\* 0-5 Volts only

### Range Information for all Instruments

Each calibration will require the following information:

Range \_\_\_\_\_  
 Flow Units \_\_\_\_\_  
 Gas \_\_\_\_\_

### For the HFC Instruments also

Upstream Pressure \_\_\_\_\_  
*(maximum & minimum)*  
 Downstream Pressure \_\_\_\_\_  
*(maximum & minimum)*  
 Does the downstream pressure change with flowrate? Y/N \_\_\_\_\_

For volumetric units the standard temperature and pressure of the unit is also required  
 0°C & 760 Torr will be used when other values are not specified



Telephone: (757) 723-6531  
 Toll Free: (800) 950-2468  
 Fax: (757) 723-3925  
 World Wide Web: <http://www.teledyne-hi.com>  
 E-mail: [hastings\\_instruments@teledyne.com](mailto:hastings_instruments@teledyne.com)  
 P.O. Box 1436  
 Hampton, VA 23661

