



# TELEDYNE HASTINGS INSTRUMENTS

Model 2002®

## FEATURES

- Combined Pirani and Piezoresistive Sensors in a Single Tube
- Wide Dynamic Range: 1000 Torr to  $1 \times 10^{-4}$  Torr
- Automatic Crossover Calibration
- Attitude Insensitive – Can Be Mounted in Any Orientation
- Fast Dynamic Response Time
- Compact Rugged Design
- Burst Pressure 150 PSIG
- Linear Per Decade Output Signal
- Custom Outputs Available

## APPLICATIONS

- Wide Range Vacuum Applications
- Process Control and Test
- Ultra-Fast Response
- General Vacuum Control
- Vacuum Furnace Control
- Loadlock System
- Transformer “DeGAS” System
- Sputtering Chambers

# DUAL SENSOR VACUUM GAUGE



## DESCRIPTION

The Model 2002, Dual Sensor Vacuum Gauge, is a wide range vacuum instrument consisting of a digital microprocessor-based display unit, two sensing elements (micro-Pirani and piezoresistive bridge) in a single tube shell, and an interconnecting cable. Together, these components provide accurate vacuum measurement over 7 decades of pressure from  $1 \times 10^{-4}$  Torr to 1000 Torr. This instrument is a new design approach based on over 60 years of experience by Teledyne Hastings Instruments (THI) with well-known pressure measurement techniques. A single tube contains both a THI patented thin film Pirani sensor and a piezoresistive sensor in a small, rugged and inexpensive package. The piezoresistive bridge is a direct force sensor which gives very accurate readings at high pressures from atmosphere down to less than 1 Torr without the concerns of gas composition. The thin film Pirani measures pressures from a few Torr down to  $1 \times 10^{-4}$  Torr. An algorithm residing in the microprocessor ensures a seamless transition between sensors. Additionally, the two sensor outputs are used in a cross calibration mode to give even higher accuracy.

### New Sensor Design

The Model 2002 sensors are mounted in a rugged corrosive resistant 316 stainless steel tube. The small packaging reduces the sensor's internal volume, significantly improving response time. The tube can be mounted in any orientation with no effect on calibration and is far more rugged than standard fragile convection driven Pirani tubes. The two sensors reside on a single gold plated Kovar header.

## Design Features (cont)

This header is welded into the stainless tube shell and will withstand positive pressures of over 150 psi.

Note: Calibration is stored within tube memory chip.

Each Model 2002 transducer contains within a programmable memory chip (EEPROM). Stored on the EEPROM are the calibration parameters for both the thin film Pirani and the piezoresistive bridge. Also contained on the EEPROM is identification information which is suitable for use in quality programs.

The Model 2002 is ideal for applications that require accuracy without the expense of costly capacitance manometers and/or small size and rugged construction without the fragility of bulky convection driven Pirani tubes.

### New Readout Design

Like the transducer, the microprocessor based controller is constructed for long trouble free life. Using the supplied gaskets, the controller can be easily converted into a NEMA 12 rated sealed enclosure. The display consists of an easily readable large green LED flat panel display with smooth operating tactile membrane switches for mode, gas, calibration, and set point configuration. The controller features a 3-digit floating point display, user selectable units (Torr, mbar, Pa), as well as a convenient user interface for flexible operation

The controller allows the user to incorporate data acquisition systems by providing a linear per decade analog output signal along with additional separate TTL input/output signals for maintaining control over various processes.

### Optional Accessories

The Model 2002 has been designed as a flexible system for easy user configuration. Mating connectors are supplied for each option.

In addition to the I/O (linear per decade analog with two TTL set points) which is standard on every HPM-2002, the user may also order one of the following options:

**RS-232** Allows the user to quickly interface the HPM-2002 to the serial port of a computer. The connection is made through a 9-pin D connector. The user may query the HPM-2002 for the pressure, set point settings, and alarm status.

**RS-485** The RS-485 version is another serial communication connection, which supports multiple units on a network through addressing. The RS-485 can be configured in either full duplex or half duplex mode.

**Dual 4-20 mA** Often used in industrial equipment, the dual 4-20 mA option gives the user two linear current outputs. The first 4-20 mA channel spans the pressure range to 1024 Torr. The second channel spans the range to 1000 mTorr.

**Dual 10 Volt** Many users prefer the simplicity of linear voltage outputs. Like the 4-20 mA version, two channels are used to span the entire pressure range of the HPM-2002.

**Dual Control Relays (1A)** Each of the above options can also include two contact relays 2 Form C (SPDT). See the Selection Chart on the back of this Product Bulletin for ordering information.

**Diagnostic Tube** The HPM-2002-DIAG allows users to verify proper operation of the HPM-2002 control unit and cabling. This diagnostic tube contains the same electronics as an HPM-2002S tube, however both sensors are replaced with known resistive loads. This allows a simulation of the voltage and power levels obtained in the crossover range of the two sensors, thereby causing the controller to indicate a pressure level of approximately 15 Torr. An EEPROM memory chip is also active within the diagnostic tube, allowing verification that the control unit can read the sensor's memory data. (Note: There is no calibration information stored in the control unit. All coefficients are stored in the individual sensor; therefore, the diagnostic tube cannot be used in any way as a calibration device.)

**Zeolite Filter** A Zeolite Filter accessory is available for protecting the sensor from contamination.

*Hastings Instruments reserves the right to change or modify the design of its equipment without any obligation to provide notification of change or intent to change.*

Viton® is a registered trademark of Dupont Performance Elastomers  
Kalrez® is a registered trademark of DuPont Dow Elastomers  
Teflon® is a registered trademark of E.I. Dupont de Nemours & Co.  
VCR® is a registered trademark of Swagelok Company.

## Specifications and Standards

<b>Performance</b>	
<b>Measuring Range</b>	1x10 <sup>-4</sup> Torr to 10 <sup>+3</sup> Torr
<b>Ambient Temperature Operating Range &amp; Compensation</b>	0°C to 50°C
<b>Accuracy (Based on N2 @ 23°C)</b>	±1.5% of reading (1000 Torr to 50 Torr) ±20% of reading (50 Torr to 1x10 <sup>-3</sup> Torr)
<b>Output (Standard)</b>	1.0 – 4.5 Volts (0.5 VDC Linear per decade)
<b>Process Control</b>	2 TTL Outputs 1 TTL Remote Zero Input
<b>Digital Readout</b>	Three green LED(0.6") – Resolution is a three digit floating point mantissa (plus exponent)
<b>Input Voltage</b>	90-260 VAC, 50 to 60 Hz, IEC receptacle. A 6 ft., 3 wire ground power cord is provided with each unit.
<b>Stability with Voltage Variation</b>	Undetectable change in reading as power fluctuates
<b>Weight (approx.) (Display, cable, and sensor)</b>	Net: 2.3 lbs. 1.0 kg Shipping: 3.4 lbs. 1.5 kg
<b>Response Time (Sensor/controller)</b>	Step change from 10 <sup>-3</sup> Torr to 760 Torr (200 milliseconds)
<b>Model 2002 Dimensions (Reference only)</b>	3.75"W x 3.75"H x 6.60"D (95mm x 95mm x 168mm) Standard DIN 43700 insert (1/4" DIN). Case constructed of NORYL – Rated UL-94 V1 (Self-extinguishing plastic).
<b>Panel Thickness</b>	Adjustable to 3/16 inches. Unit mounts into 3.62 in. (92 mm) square hole
<b>Sensor Mounting</b>	Any position without recalibrating
<b>Sensor Internal Volume</b>	< 1.5 cc
<b>Wetted Material</b>	Silicon Nitride, Silicon, Gold, Pyrex, 316 Stainless Steel, UHV Epoxy
<b>Calibrated for Nitrogen</b>	Factory calibrated for nitrogen. Conversion factors for many other gases are selectable (consult instruction manual).
<b>Burst Pressure (tube)</b>	150 psig
<b>Proof Pressure *</b>	30 psig
* Maximum pressure above which may cause permanent damage	

# Outline Drawing

MODEL 2002 (STANDARD CONFIGURATION)

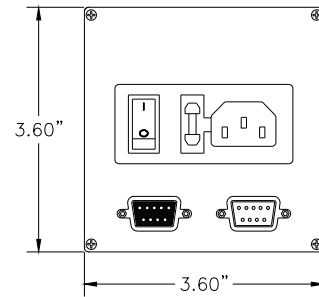
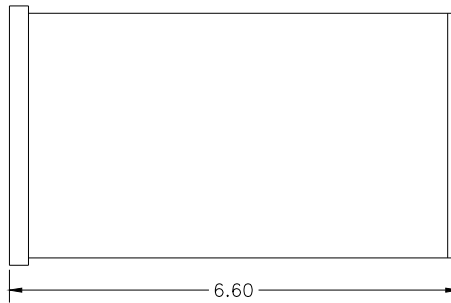
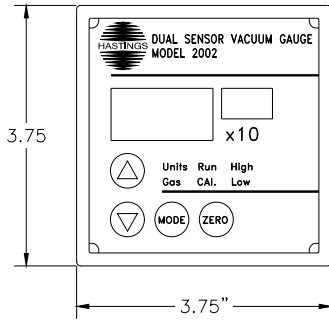

MODEL 2002 WITH RS-232 OPTION

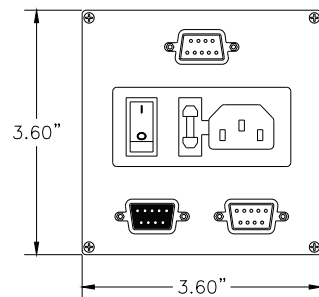
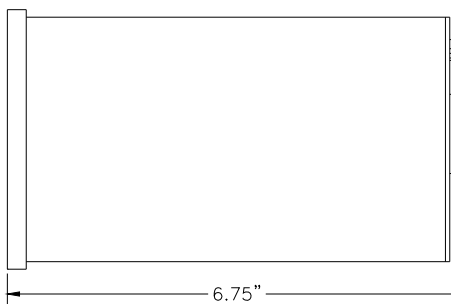
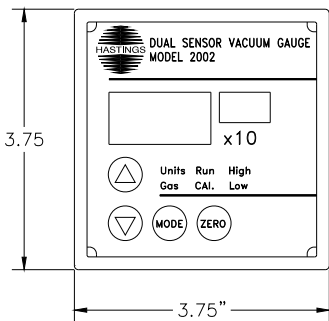

MODEL 2002 W/ DOUBLE POINT CONTROL RELAYS

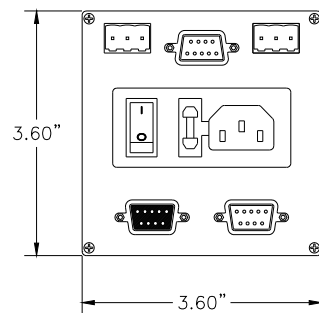
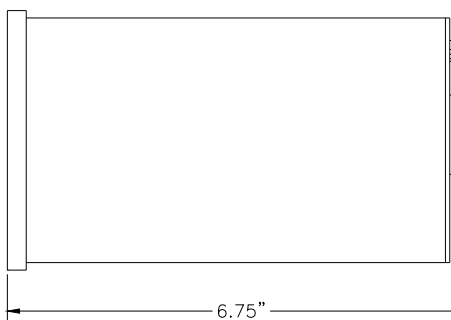
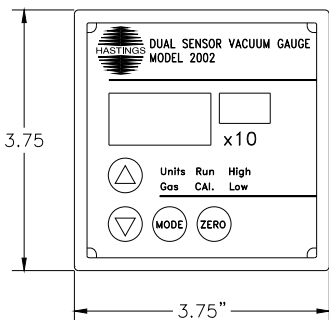

Outline Drawing

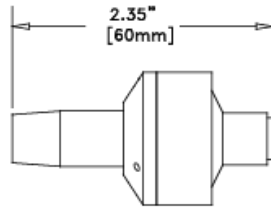
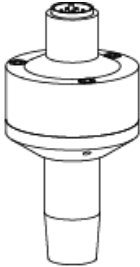

1/8" NPT (HPM-2002-01)

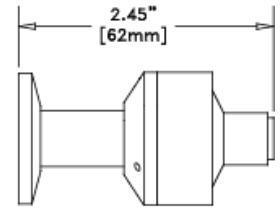
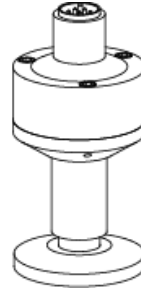

KF-16 (HPM-2002-05)

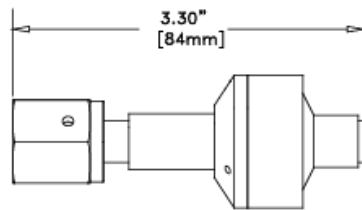
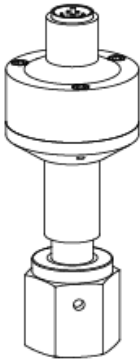

1/4" VCR (HPM-2002-02)

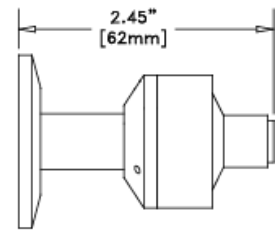
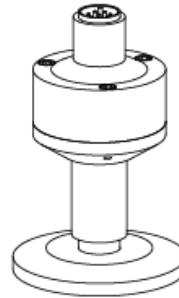

KF-25 (HPM-2002-06)

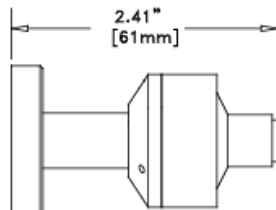
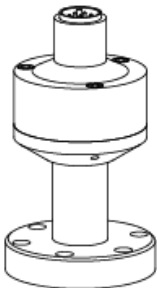

Mini Conflat™ (HPM-2002-03)

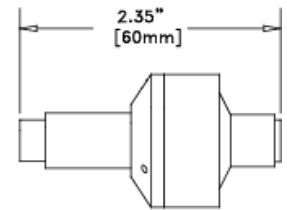
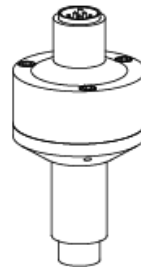

1/2" OD Smooth tube (HPM-2002-07)

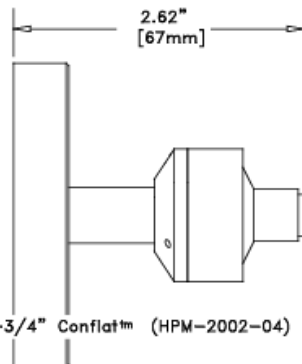
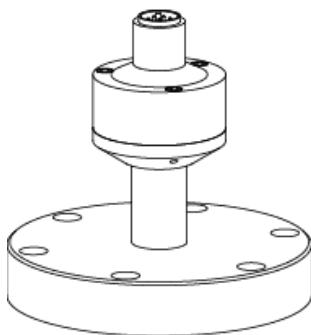

2-3/4" Conflat™ (HPM-2002-04)

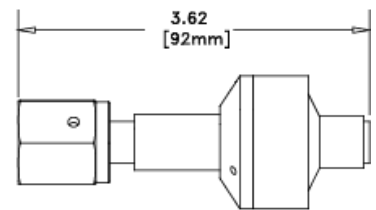
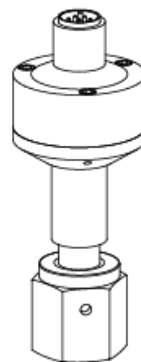

1/2" VCR (HPM-2002-08)

# Selection Chart

Model No.
HPM 2002

Cal	Gas Config	Output Signal

Order No.	Options
Calibration	
01	Standard (w/Cert. of Conformance)
02	NIST Certificate w/Data
99	Custom Calibration with specified gas (consult factory)

Gas configuration	
00	Nitrogen (Standard)
01	Argon
02	Helium
03	Water Vapor
99	Other (consult factory)

Output Signal	
01	Analog with 2 TTL set points (Std)
02	RS-232
03	Dual Control Relays (1A)
04	Dual 4-20 mA
05	Dual 10 V Linear
06	RS-485 Half Duplex
07	RS-485 Full Duplex
12	RS-232 w/Dual Control Relays (1A)
14	Dual 4-20 mA w/Dual Control Relays (1A)
15	Dual 10 V Linear w/Dual Control Relays (1A)
16	RS-485 Half Duplex w/Dual Control Relays (1A)
17	RS-485 Full Duplex w/Dual Control Relays (1A)

Shipment includes
HPM-2002
2002 Gauge Tube
9-Pin "D" Connector-Kit
2nd 9-Pin "D" Connector-Kit (for RS and 4-20 mA options only)
IEC Power Cord
Panel mounting Hardware

\*Note: Gauge tube and cable are sold separately

Model No.
HPM 2002S

System Connection

Order No.	Options
Connections	
01	1/8" NPT
02	1/4" VCR™
03	1.33" Mini Conflat™
04	2.75" Conflat™
05	KF-16™
06	KF-25™
07	1/2" O.D. Smooth Tube
08	1/2" VCR

Model No.
CB 2002

Length Option

Order No.	Options
Cable	
D01	Cable: 2 Meters (6.2 ft)
D02	Cable: 5 Meters (15.5 ft)
D99	Custom Cable (XX Meters)

Accessories	
Part Number	Description
HPM-2002-OBE-DIAG	Diagnostic Tube
65-724	Zeolite Filter